

SMMS 
SUPER MODULAR MULTI SYSTEM



INDEX

Introduction	03
SMMS-e features energy saving	06
Capacity range	08
Operating temperature range	09
Enhanced comfort	10
System control	11
DC twin-rotary compressor	12
Heat exchanger	13
Precise refrigerant flow	14
Reliability	15
Piping design flexibility	16
Slimmer pipe size	17
Propeller fan	18
Connectable indoor unit	19
SMMS-e wave tool	20
Outdoor units	
Outdoor units line-up	22
Outdoor units specifications	24
Outdoor units external view drawings	30
Indoor units	
Indoor units line-up for SMMS-e	32
4-way air discharge cassette type	34
Compact 4-way cassette (620 x 620) Type	36
2-way air discharge cassette Type	38
1-way air discharge cassette type	40
Concealed duct type	42
Concealed duct high static pressure type	44
Slim duct type	46
Ceiling type	48
High-wall type (7 series)	50
Console type	51
Floor standing cabinet type	52
Floor standing concealed type	53
Floor standing type	54
Fresh air intake indoor unit type	55
Indoor unit accessories for SMMS-e	57
Air-conditioning management system	58
Remote controller	60
Open network systems	64
VRF DX coil interface	66
Control devices	67
Safety precautions	69



> **Toshiba Air Conditioning Absolute comfort**

Toshiba's commitment to world-class efficiency, versatile scalability and trusted quality results in cutting-edge technology that gives our customers industry leading solutions for their needs. Toshiba Air Conditioning is a global provider of a comprehensive range of innovative air conditioning solutions with trusted, world class reliability. With several "World's Firsts" to its credit, Toshiba Air Conditioning has been the reliable source of next generation, energy efficient products and solutions for over 30 years.

Toshiba's commitment to people drives attention to detail at every stage of the development process, from design to user field tests. As a result, Toshiba products and systems feature higher standard of indoor air quality, low sound levels, energy savings and unrivaled comfort along with environmental sustainability.

> **A Global Innovation Network**

Toshiba Air Conditioning has research and development centers across Japan, Europe, Thailand and China. Its global research activities are managed and integrated to ensure all research sites collaborate to provide innovative solutions to customers across the world. The Toshiba brand holds more than 1200 patents in Japan and abroad, an outstanding number for any company.

Each year since 1994, Toshiba Air Conditioning has received prestigious awards for its significant achievements in air conditioning and in November 2020 the world's-first inverter split air conditioner that Toshiba developed and mass produced for commercial and residential applications in 1980 and 1981, respectively, was recognized by the Institute of Electrical and Electronics Engineers (IEEE) as an IEEE milestone for the historic significance of the achievement in electrical and electronics industry.

This demonstrates Toshiba's innovative spirit and a relentless drive to improve its products and systems.

> ALWAYS ONE STEP AHEAD

First inverter-based air conditioner



First Toshiba VRF (MMS), modular system up to 40 HP



Super Power Eco using DC inverter rotary compressor & R410A



First digital inverter control



Toshiba's first mini VRF (MiNi SMMS)



1981 1986

1993

2000

2001

2003

2006 2010

Super Multi, multi air conditioner for buildings

Digital twin rotary air conditioner



DC hybrid inverter



VRF (SMMS), Super Modular Multi System R410A



VRF (SMMS-i)



Monosplit R32



Entry Tier Model

Monosplit range DAISEIKAI 9 R32



Full Multisplit range



Monosplit SEIYA R32



Monosplit SHORAI Edge R32



2015

2016

2017

2018

2019

2020

VRF (SMMS-e) with NFC service tool



VRF (SHRM-e), Super Heat Recovery Multi System



Big DI, light commercial large-capacity air conditioner



Full light commercial range R32 DI R32 SDI R32



DI 3.5HP R32



IEEE Milestone



Inverter Air conditioners

TOSHIBA VRF History

1985

Multi System AC



Multi System AC

1986

Super Multi



Multi controller

1994

Wide Multi



Optimal ref control
free branch piping

2000

MMS



Module CDU
Oil balance control

2003

SMMS



All inverter control
R410A DC twin rotary comp

2005

Mini SMMS



Small capacity VRF

2010

SMMS-i



3 inverter control,
High energy efficiency

2012

SMMS-i
High Ambient



3 inverter control,
Tropical VRF

2015

SMMS-e



Expanded product/
operation range, wave tool

2016

Mini SMMS-e



Small capacity hi-ambient VRF



Over **30** years of experience
with inverter technology

35 Years experience
in VRF technology



Energy saving

High efficiency performance

EER
■ Rated *

Cooling mode

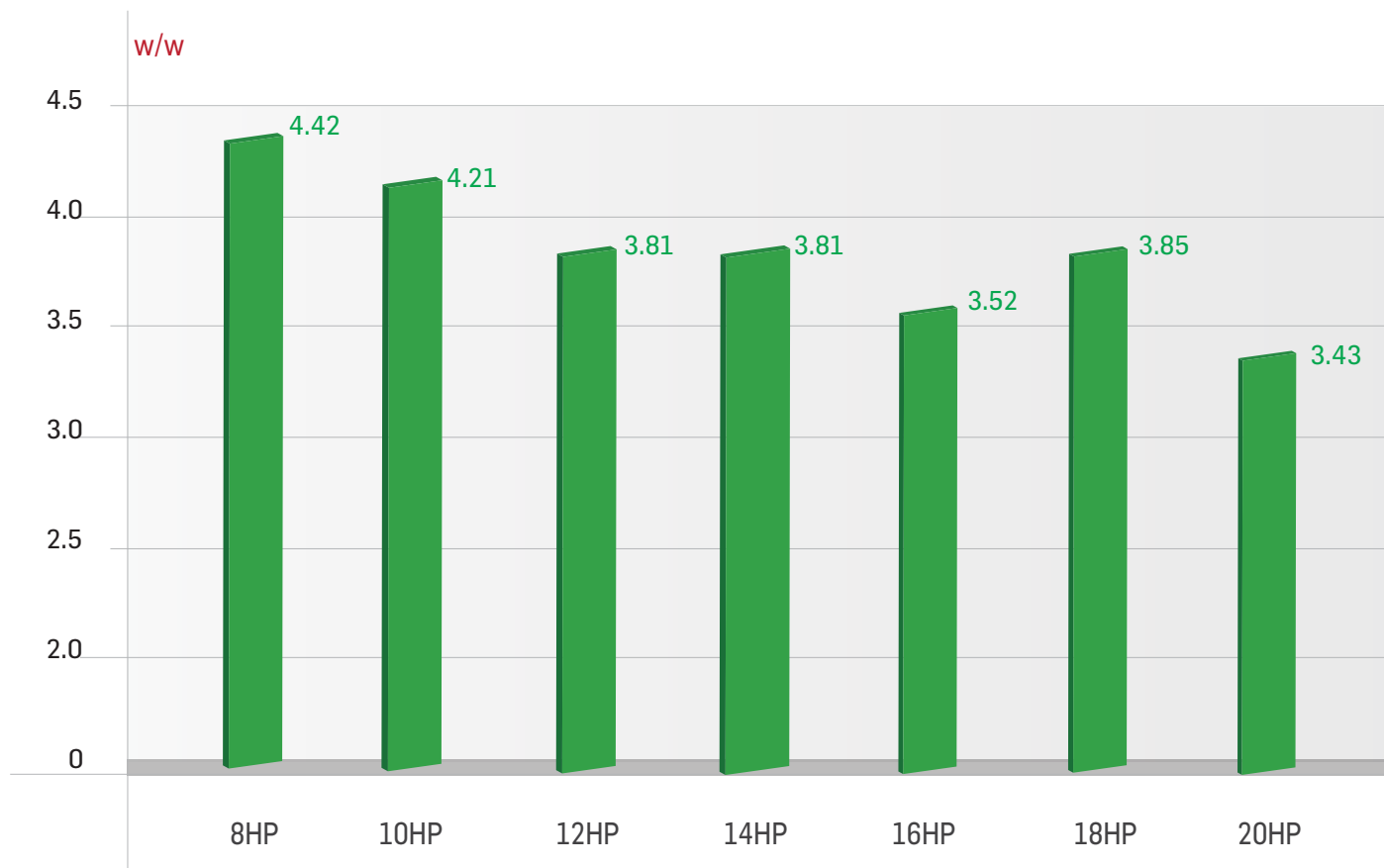

Note:

The source voltage must not fluctuate more than 10%.

* Indoor temperature: 26.7°C DB/19.4°C CWB, outdoor temperature: 35°C DB (AHRI 1230 standard), power input of indoor units included.



Energy saving

The overall capacity range and the highest EER of 4.42 (15.08)
The SMMS-e offers truly excellence as the industry's top class in energy saving.



Note:
The source voltage must not flucture more than 10%.
* Indoor temperature: 26.7°C DB/19.4°CWB, outdoor temperature: 35°C DB (AHRI 1230 standard), power input of indoor units included.



Capacity range

Increased single module capacity

SMMS-e comes with 3 new larger capacity units, producing up to 20HP on a single module platform.



System capacity expanded

With the SMMS-e, it is now possible to connect up to 56HP in one system.

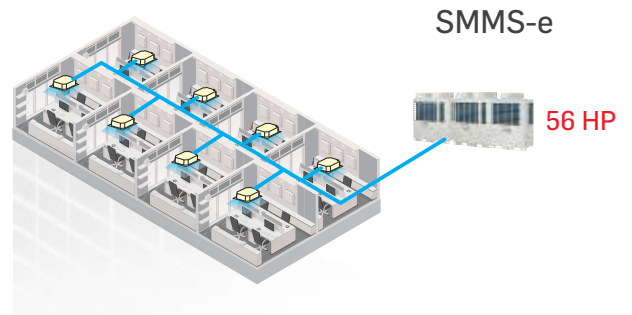

Installation flexibility

The expansion of the maximum combined capacity from 48 to 56HP in one system helps save time and expense on the purchase and installation of additional units/systems. The new compact unit design also increases flexibility on installation and increases ROI with a small foot print.

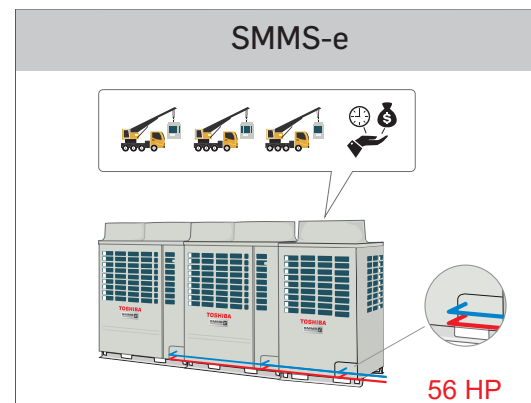

SMMS-e is capable of covering up to 20HP with a single module. This reduces pipe work and overall installation time.



Operating temperature range

Outdoor temperature range

Utilizing the newly designed compressor, Mini SMMS-e operates efficiently in a wide ambient temperature range of -25°C to 54°C.

Operation ambient temperature expansion

(Cooling : CDB, Heating : CWB)

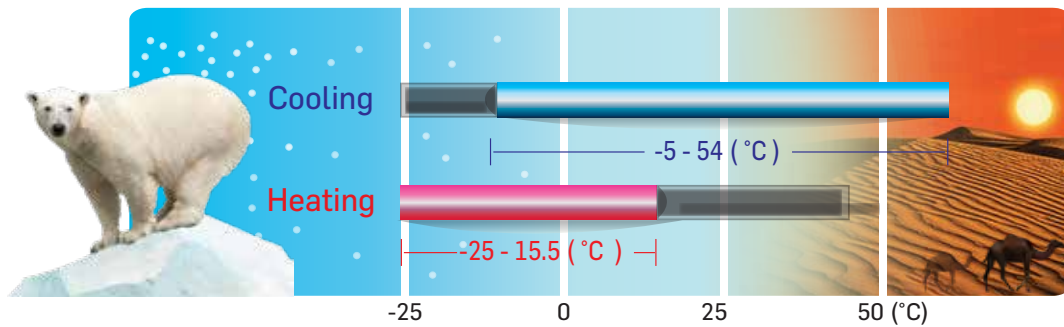

Note : Based on equivalent piping length of 7.5 m and piping height difference of 0 m.

Heat pipe technology*

Thank to excellent heat sink with heat pipe technology, SMMS-e product ensure high reliability at high ambient temperature.

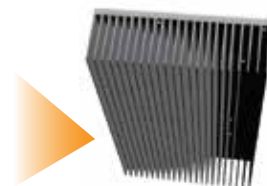
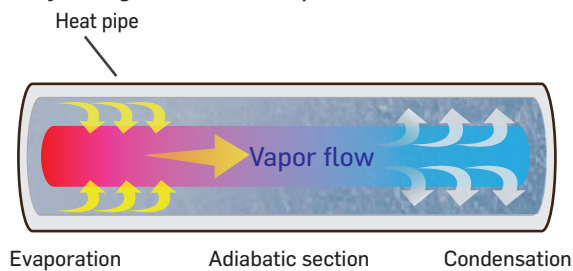

Heat sink with heat pipe
- In order to cool for inverter



*18-20 HP - High ambient model

The external static pressure

The SMMS-e units are suitable for challenging installations where high external static pressure performance is required.

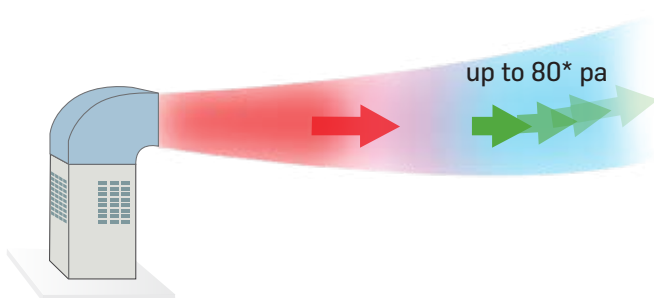

*Note: For ESP consult to local sales person.

Air flow simulation diagram

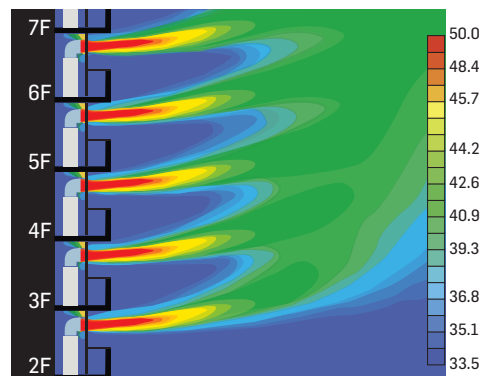

Note : This result is an analytical simulation.



Enhanced Comfort

New intelligent VRF control

Toshiba systems with intelligent VRF control provide levels of comfort other systems simply cannot match. That's because differing pipe lengths in commercial buildings result in inconsistent levels of performance, especially when several indoor units are connected to a system. This imbalance is caused by pressure loss and thermal leaks that inhibit the optimum refrigerant flow to each indoor unit.

For example, without intelligent control, upper floor indoor units within VRF systems place loads on the refrigerant supply. This causes a delay before enough refrigerant reaches the lower floors to deliver efficient levels of operation.

Without intelligent VRF control, refrigerant flows unevenly throughout the structure, typically oversupplying areas closer to the outdoor unit and undersupplying areas that are farther away.

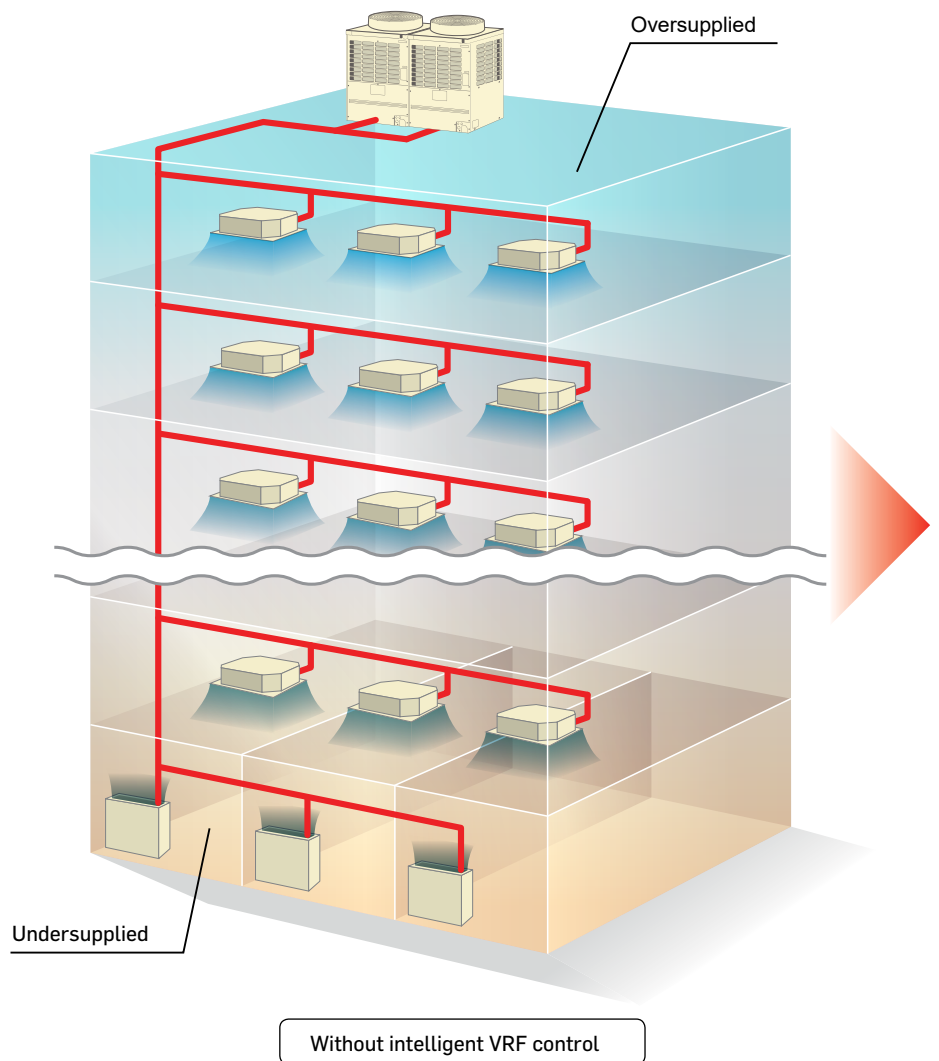



Total system control

Total system control and consistent room-to-room temperature

The Toshiba intelligent VRF control overcomes these issues by providing precise control of indoor units. The intelligent VRF control sends more refrigerant to areas that need it, and supplies less refrigerant to areas that don't and refrigerant is distributed evenly regardless of line length. As a result, occupants enjoy greater overall comfort whether they are closest to the outdoor unit or farthest away.

Toshiba SMMS-e systems monitor the flow of refrigerant to each indoor unit while tracking the model number of each indoor unit and the pipe length between each indoor unit and the outdoor unit, as well as data on operating conditions. The system computes the amount of refrigerant required by each indoor unit and controls the unit's pulse motor valve to ensure optimal supply across the system even with a height difference between outdoor unit and indoor unit of up to 90 meter.

With intelligent VRF control, Toshiba delivers consistent and customized, room to room comfort across several floors of a commercial structure.

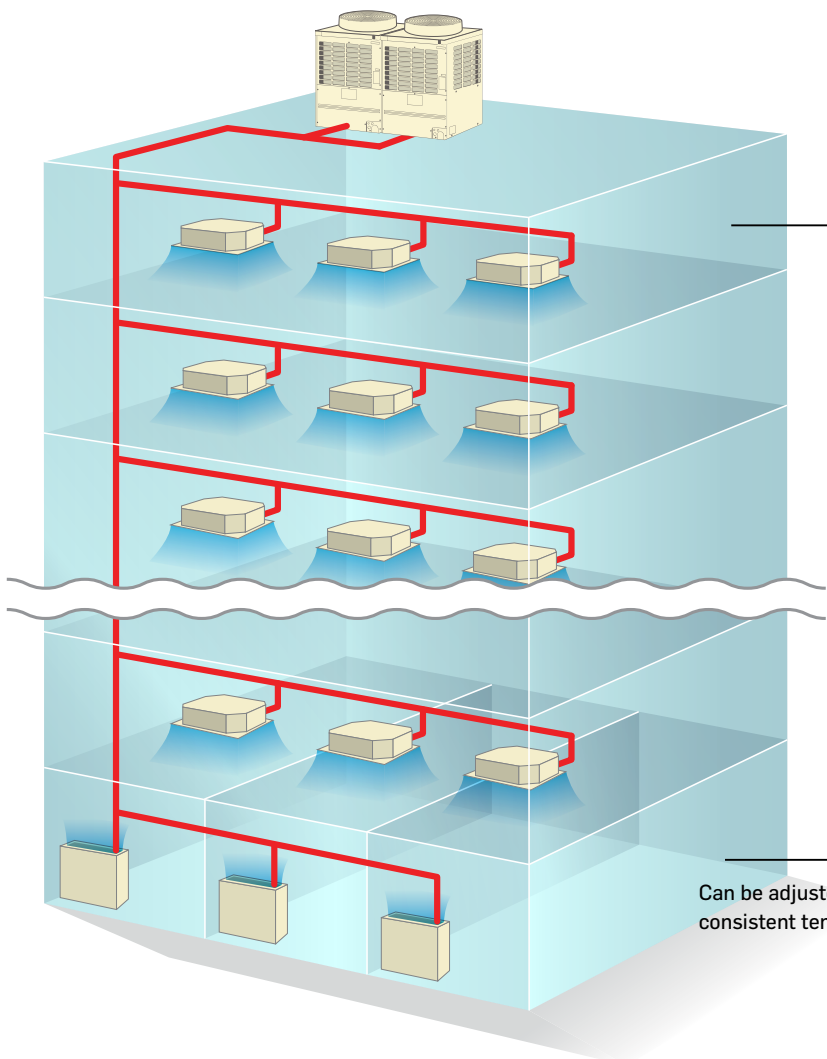

Can be adjusted to maintain consistent temperature

With intelligent VRF control



DC twin rotary compressor

Wide range compressor

More powerful and efficient with cutting-edge technology the DC twin rotary compressor operates in of compressor – DC Twin-Rotary operates in a wider rotation speed range.



SMMS-e

Displacement volume

64
cm³

DLC coated vane

Increased hardness of the DLC coated vane reduces friction and increases both reliability and performance.

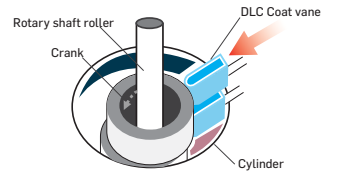

* DLC: Diamond Like Carbon

2-stage vane

The innovative design of the 2-stage vane reduces friction while increasing hardness and enhancing performance to optimum values.

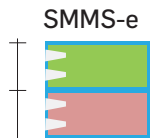
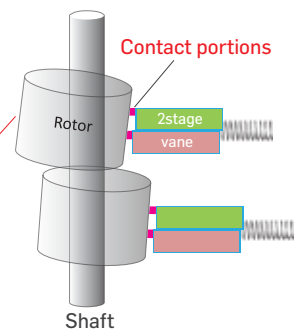

Infinity variable control

The Infinity Variable control adjusts compressor rotation speed in near seamless 0.1 Hz steps. Responding precisely to the capacity needs of the moment, this fine control minimizes energy loss when changing frequencies, and also creates a comfortable environment with negligible temperature variations.

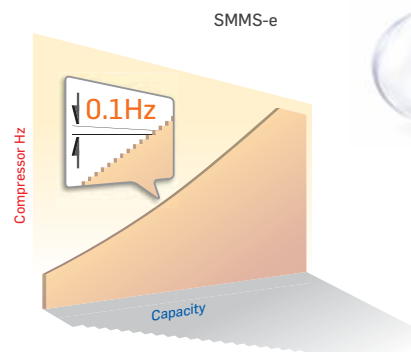

Ultra-precise 0.1 Hz control over compressor rotation speed



Heat exchanger

New heat exchanger

The new heat exchanger of Toshiba's SMMS-e VRF systems is provided with an additional row (increased to 3 from 2, increasing surface area of the total piping by 13%.

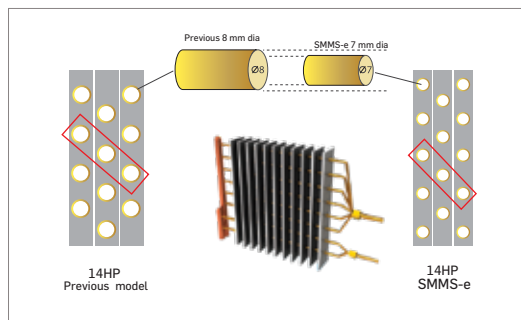
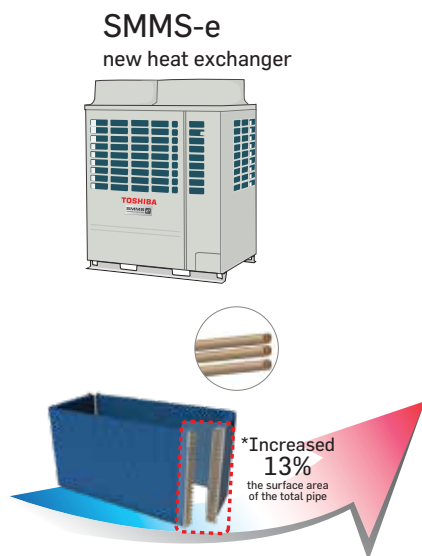

Variable heat exchanger

New system controls allows the outdoor unit to select the most efficient heat exchanger size, which matches the capacity load in order to provide higher energy savings.

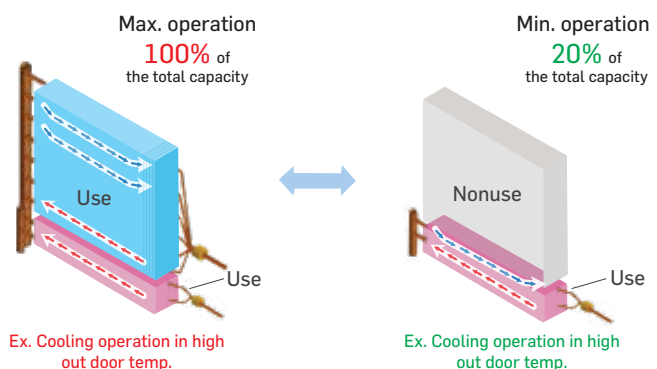

4-way heat exchanger can realize balanced airflow

Heat exchangers are located on all four sides of the outdoor unit, ensuring air flow is equal in all directions.

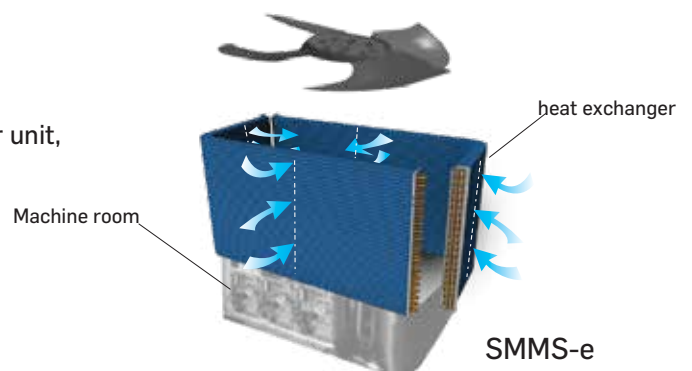

* For higher capacity model.



Precise refrigerant flow

One of the keys to delivering precision refrigerant flow and enhanced comfort is the Toshiba pulse motor valve (PMV) control. The PMV control prevents refrigerant from flowing to indoor units that are not operating. The system reduces bypass loss and achieves tighter control over the compressor capacity of the outdoor unit.

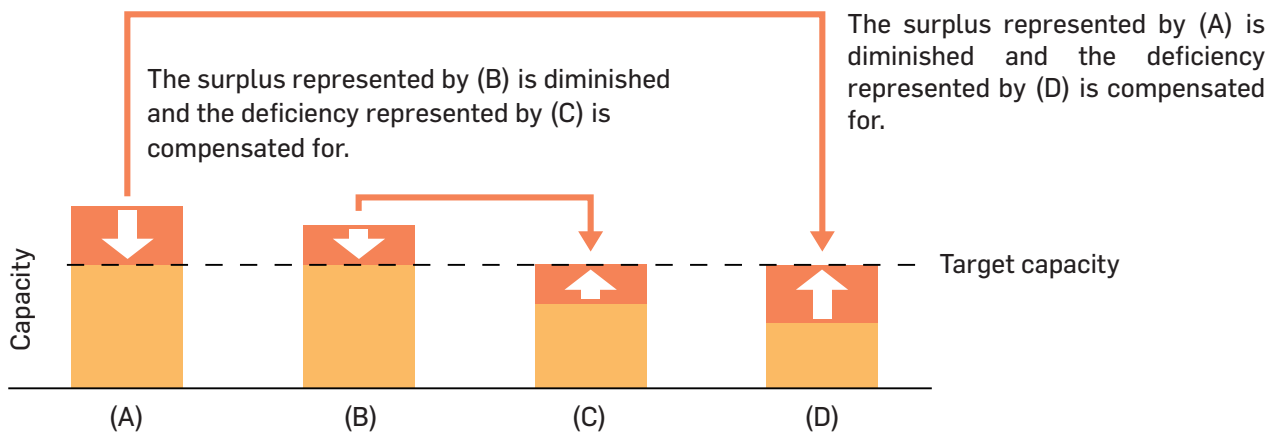
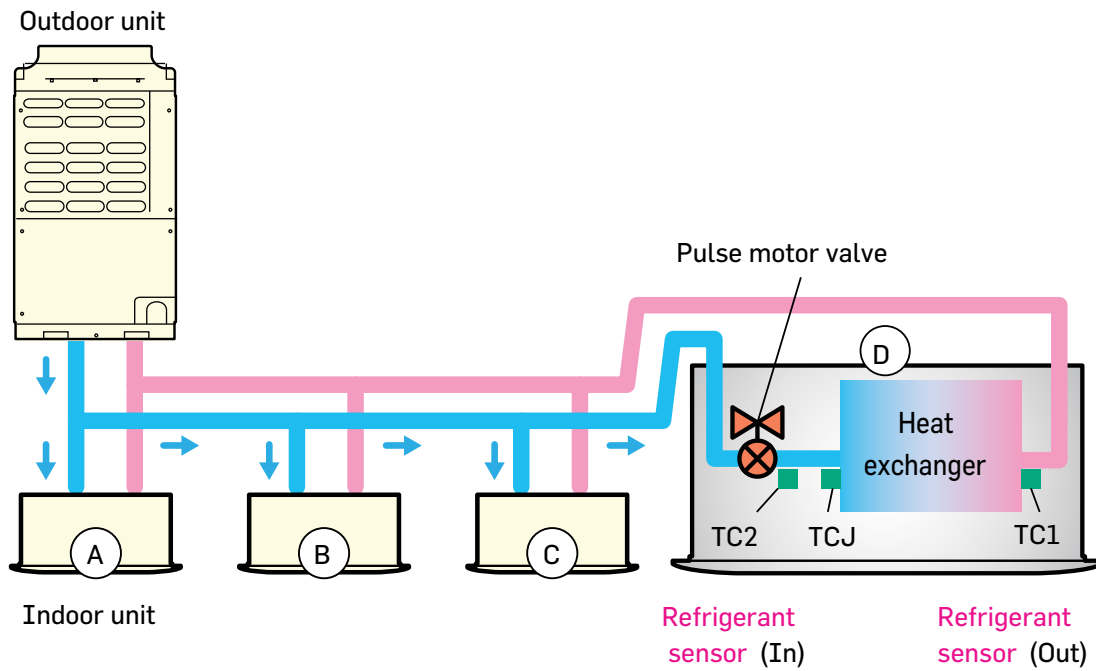



Reliability

Backup operation

In case of a compressor failure, SMMS-e can keep working with the backup operation under All Inverter Control to compensate a failed compressor or header unit. This backup operation is available in both a single system or as a module.

Single outdoor unit backup

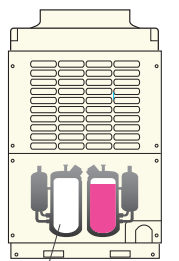

Failed compressor

Module outdoor unit backup

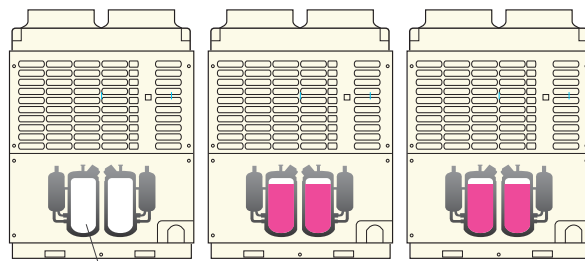

Failed outdoor unit

Reliability rotational control

The rotational control in SMMS-e is designed to improve system reliability by controlling the operation of each compressor to work equally under variable conditions.

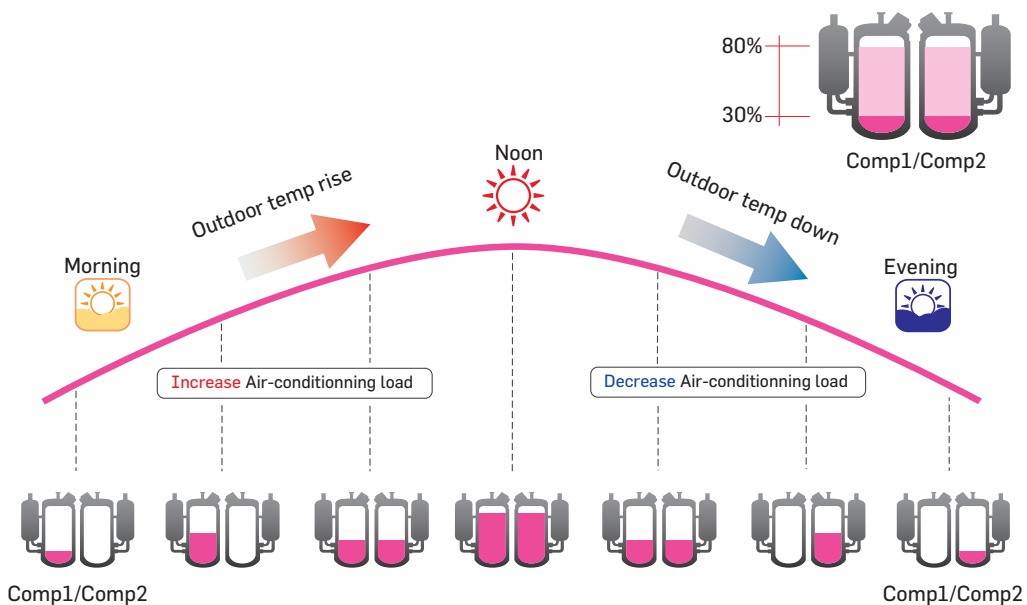



Piping design flexibility

Total piping length

Applied with Toshiba's unique and greatly improved technology, SMMS-e can reach up to 1,000 meters maximum piping length.

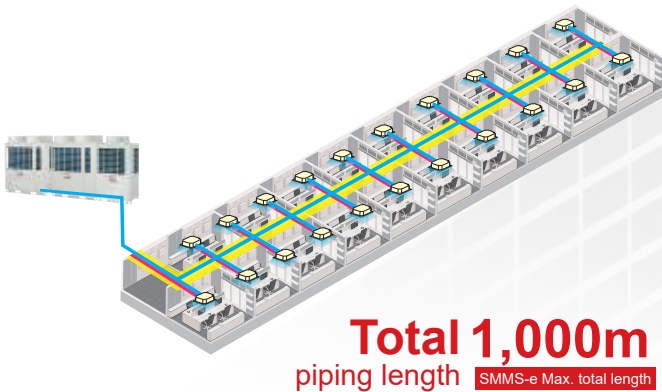

Farthest pipe from 1st branch

The Toshiba SMMS-e VRF System offers increase convenience with an exemplary piping distance of 90 meters from the first branch to the furthest indoor unit. This increases the flexibility of installation and finds great demand within any large installation and hotel and office buildings.

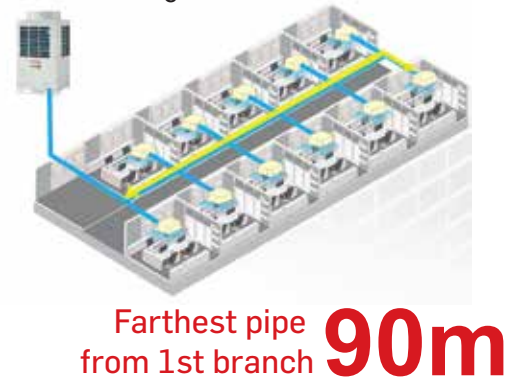

Farthest equivalent length

The maximum equivalent distance between outdoor unit and farthest indoor unit tops at 235 meters, which tops the industry class.



Height between indoor units

Another industry top class feature is the maximum vertical distance between indoor units which reaches up to 40 meters equal to an entire 11 storied building. SMMS-e's enhanced piping capabilities result in more benefits for system design, installation flexibility, as well as less installation cost.



Piping capabilities summary

The piping flexibilities and feature associated with the Toshiba SMMS-e VRF system offer industry leading benefits in system design, ease of installation and reduced installation costs.

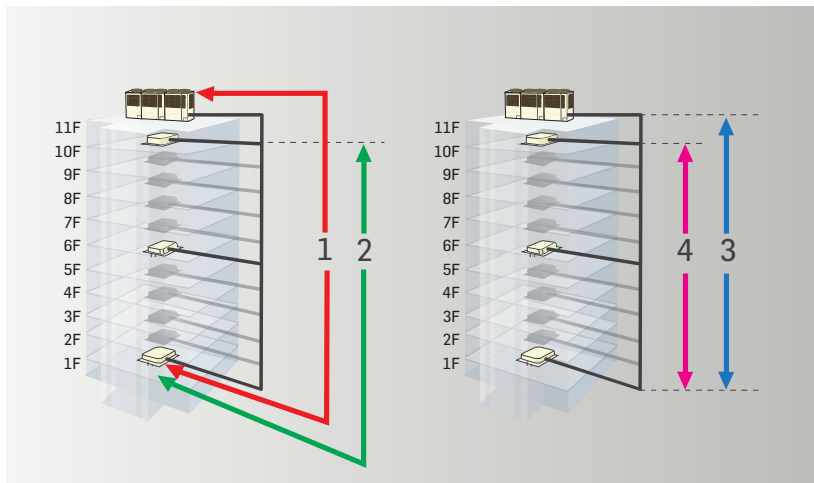

Total length	1,000m*
1. Farthest equivalent length	235m
2. Farthest pipe from 1st branch	90m**
3. Height between outdoor unit - indoor unit (outdoor unit above/below)	90m***/40m
4. Height between indoor unit - indoor unit	40m

- * : 34HP combination or more
- ** : 65m if the height piping length between outdoor unit and indoor unit is more than 3m
- *** : Be sure to refer to local sales person for details of these conditions and requirements.

Slimmer pipe size

Piping saving costs

With the sub-cool heat exchanger less refrigerant is needed therefore now it is possible to use smaller pipes and save in installation costs.

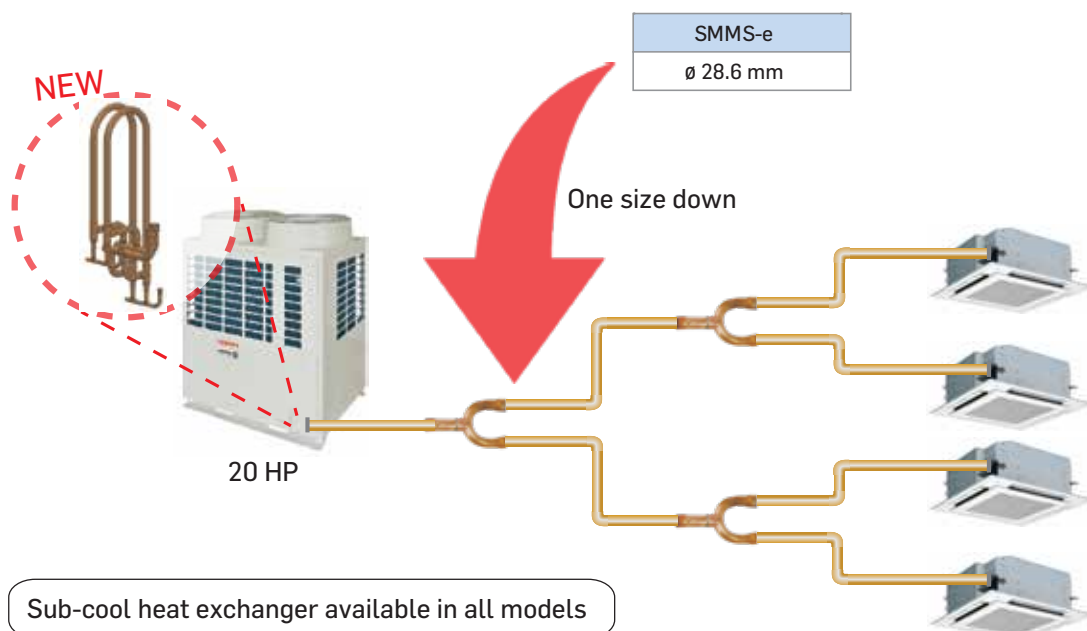

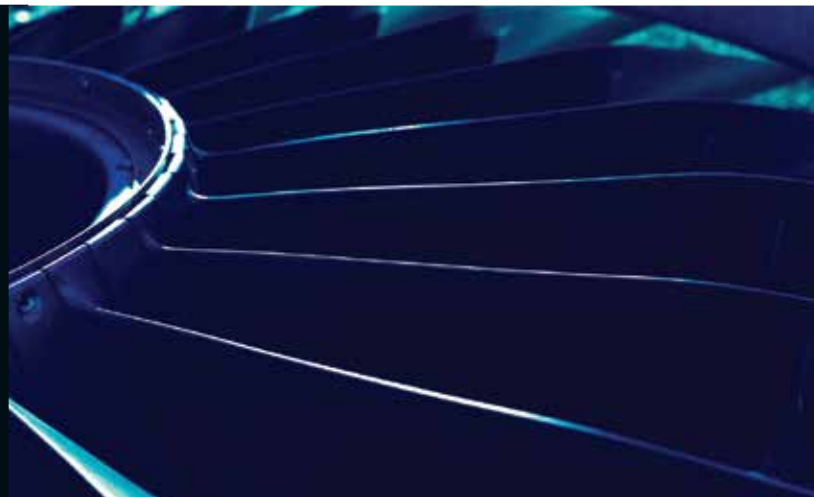





Propeller fan

New advanced blade shapes for a better air flow management

Every single blade is designed with a unique profile, a solution that guarantees a smoother air flow without turbulences. The new propeller type fan delivers the same amount of air with less sound pressure level.

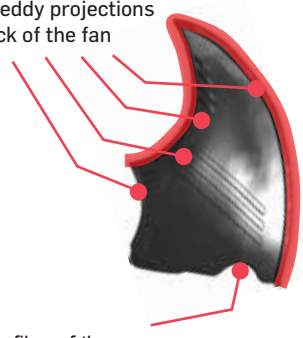

Each blade has a unique profile	Design improvements
<div style="display: flex; justify-content: space-around;"> <div style="text-align: center;"> <p>A</p>  </div> <div style="text-align: center;"> <p>B</p>  </div> </div> <div style="display: flex; justify-content: space-around; margin-top: 20px;"> <div style="text-align: center;"> <p>C</p>  </div> <div style="text-align: center;"> <p>D</p>  </div> </div>	<div style="text-align: center;"> <p>New anti-eddy projections on the back of the fan</p>  </div> <div style="text-align: center; margin-top: 20px;"> <p>New profiles of the reverse-arc shaped wings</p> </div>





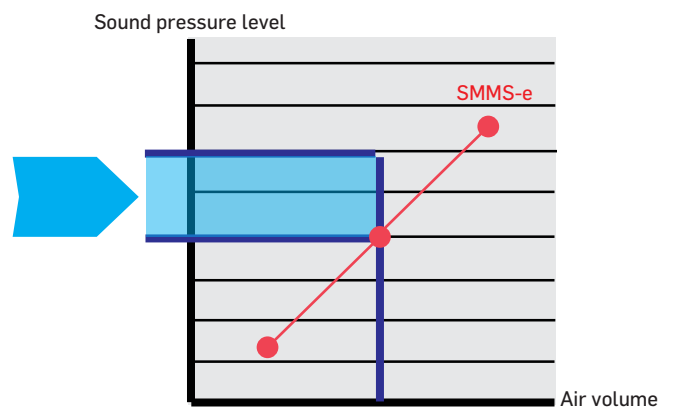









In comparison with the previous fan

In the same working conditions the new design of the propeller fan ensures a reduction of 1.5 dB compared to the previous models.





Connectable no. of indoor unit

Indoor lineup		Cooling capacity													
		2.2 0.8	2.8 1.0	3.6 1.25	4.5 1.7	5.6 2.0	7.1 2.5	8.0 3.0	9.0 3.2	11.2 4.0	14.0 5.0	16.0 6.0	22.4 8.0	28.0 10.0	
4-way air discharge cassette type		[Bar chart showing capacity for 2.2-16.0 kW]													
Compact 4-way cassette type (620 x 620)		[Bar chart showing capacity for 2.2-5.6 kW]													
2-way air discharge cassette type		[Bar chart showing capacity for 2.2-11.2 kW]													
1-way air discharge cassette type		[Bar chart showing capacity for 2.2-7.1 kW]													
Slim duct type		[Bar chart showing capacity for 2.2-7.1 kW]													
Concealed duct high static pressure type		[Bar chart showing capacity for 4.5-28.0 kW]													
Concealed duct type		[Bar chart showing capacity for 2.2-16.0 kW]													
Ceiling type		[Bar chart showing capacity for 4.5-11.2 kW]													
High wall type Series 7		[Bar chart showing capacity for 2.2-7.1 kW]													
Floor standing concealed type		[Bar chart showing capacity for 2.2-7.1 kW]													
Floor standing cabinet type		[Bar chart showing capacity for 2.2-7.1 kW]													
Console type		[Bar chart showing capacity for 2.2-5.6 kW]													
Fresh air intake indoor unit type		[Bar chart showing capacity for 11.2-28.0 kW]													
Floor standing type		[Bar chart showing capacity for 4.5-11.2 kW]													



SMMS-e wave tool

With the SMMS-e wave Tool, facility managers and technicians can read and write data from outdoor units to smart phones with the need of connecting to a PC or opening the cabinet.

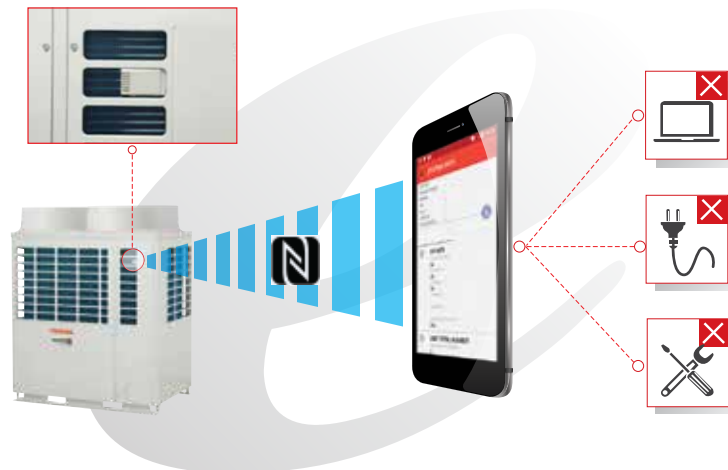

By the new smart phone application, the testing and commissioning can be done without opening the cabinet.



*For smartphone's specification refer technical manual.

Data Availability

Product data, system data, fault history or testing and commissioning information can all be easily obtained even if the unit is under service or maintenance or there is a power failure. All data can be easily sent to the distant offices via email. Toshiba SMMS-e makes it possible for facility managers, service managers and technicians to receive required system data and information for validating system operation by e-mail without having to move from the office.

In case of below situation

- ✓ Installation
- ✓ Service maintenance
- ✓ Power failure

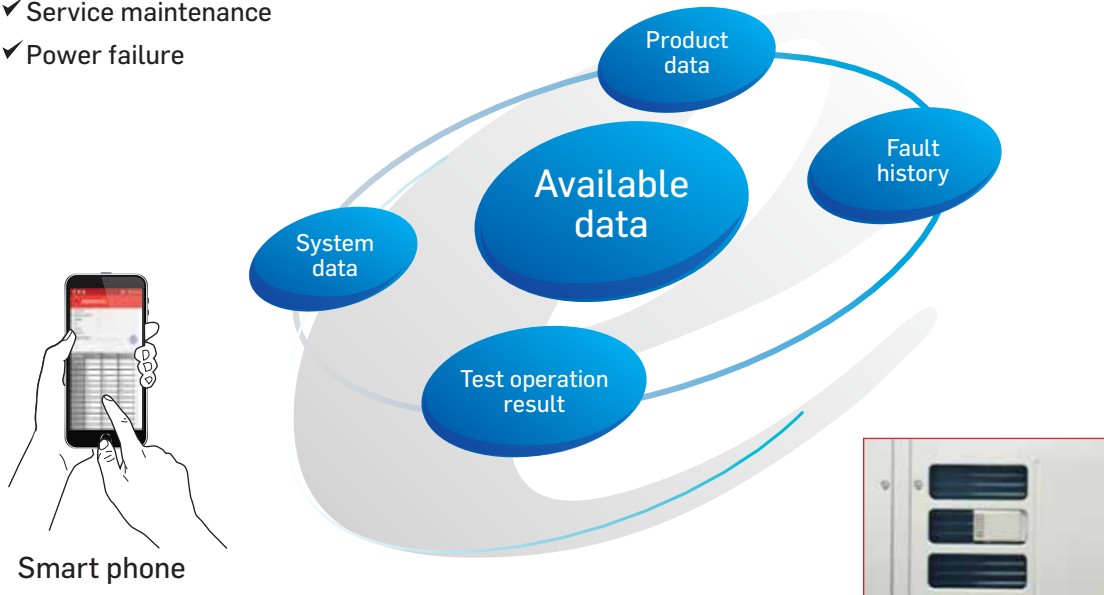





Outdoor units

Standard model

								
Capacity		8HP	10HP	12HP	14HP	16HP	18HP	20HP
Model Name (MMY-)	60 Hz	MAP0806HT7P-ME	MAP1006HT7P-ME	MAP1206HT7P-ME	MAP1406HT7P-ME	MAP1606HT7P-ME	MAP1806HT7P-ME	MAP2006HT7P-ME
Cooling capacity*	(kW)	22.4	28.0	33.5	40.0	45.0	50.4	56.0
Cooling capacity*	(kW)	20.3	25.2	26.8	32.5	36.0	42.8	44.8
Heating capacity	(kW)	25.0	31.5	37.5	45.0	50.0	56.0	63.0
No's of connectable Indoor units		13	16	20	23	27	30	33

									
Capacity		22HP	24HP	26HP	28HP	30HP	32HP	34HP	
Model Name (MMY-)	60 Hz	AP2216HT7P-ME	AP2416HT7P-ME	AP2616HT7P-ME	AP2816HT7P-ME	AP3016HT7P-ME	AP3216HT7P-ME	AP3416HT7P-ME	
Units in combination (MMY-MAP)		1206HT7P-ME 1006HT7P-ME	1206HT7P-ME 1206HT7P-ME	1406HT7P-ME 1206HT7P-ME	1406HT7P-ME 1406HT7P-ME	1606HT7P-ME 1406HT7P-ME	1606HT7P-ME 1606HT7P-ME	1806HT7P-ME 1606HT7P-ME	
Cooling capacity*	(kW)	61.5	67.0	73.5	80.0	85.0	90.0	95.4	
Cooling capacity*	(kW)	52.0	53.6	59.3	65.0	68.5	72.0	78.8	
Heating capacity	(kW)	69.0	75.0	82.5	90.0	95.0	100.0	106.0	
No's of connectable Indoor units		37	40	43	47	50	54	57	

								
Capacity		36HP	38HP	40HP	42HP	44HP	46HP	48HP
Model Name (MMY-)	60 Hz	AP3616HT7P-ME	AP3816HT7P-ME	AP4016HT7P-ME	AP4216HT7P-ME	AP4416HT7P-ME	AP4616HT7P-ME	AP4816HT7P-ME
Units in combination (MMY-MAP)		1806HT7P-ME 1806HT7P-ME	2006HT7P-ME 1806HT7P-ME	2006HT7P-ME 2006HT7P-ME	1406HT7P-ME 1406HT7P-ME 1406HT7P-ME	1606HT7P-ME 1406HT7P-ME 1406HT7P-ME	1606HT7P-ME 1606HT7P-ME 1406HT7P-ME	1606HT7P-ME 1606HT7P-ME 1606HT7P-ME
Cooling capacity*	(kW)	100.8	106.4	112.0	120.0	125.0	130.0	135.0
Cooling capacity*	(kW)	85.6	87.6	89.6	97.5	101.0	104.5	108.0
Heating capacity	(kW)	112.0	119.0	126.0	135.0	140.0	145.0	150.0
No's of connectable Indoor units		60	64	64	64	64	64	64

					
Capacity		50HP	52HP	54HP	56HP
Model Name (MMY-)	60 Hz	AP5016HT7P-ME	AP5216HT7P-ME	AP5416HT7P-ME	AP5616HT7P-ME
Units in combination (MMY-MAP)		1806HT7P-ME 1606HT7P-ME 1606HT7P-ME	1806HT7P-ME 1806HT7P-ME 1606HT7P-ME	2006HT7P-ME 2006HT7P-ME 1406HT7P-ME	2006HT7P-ME 2006HT7P-ME 1606HT7P-ME
Cooling capacity*	(kW)	140.4	145.8	152.0	157.0
Cooling capacity*	(kW)	114.8	121.6	122.1	125.6
Heating capacity	(kW)	156.0	162.0	171.0	176.0
No's of connectable Indoor units		64	64	64	64

* Power: 3phase 4wires 60Hz 380V

* The source voltage must not fluctuate more than 10%.

* Rated conditions

* Cooling: Indoor air temperature 26.7°C DB/19.4°C WB, outdoor air temperature 35°C DB (AHRI 1230 standard)



* Cooling: Indoor air temperature 26.7°C DB/19.4°C WB, outdoor air temperature 46°C DB (AHRI 1230 standard)

Heating: Indoor air temperature 20°C DB, outdoor air temperature 7°C DB/6°C WB

High efficiency model

				
Capacity	16HP	18HP	20HP	30HP
Model Name (MMY-) 60 Hz	AP1626HT7P-ME	AP1826HT7P-ME	AP2026HT7P-ME	AP3026HT7P-ME
Units in combination (MMY-)	MAP0806HT7P-ME MAP0806HT7P-ME	MAP1006HT7P-ME MAP0806HT7P-ME	MAP1006HT7P-ME MAP1006HT7P-ME	MAP1006HT7P-ME MAP1006HT7P-ME MAP1006HT7P-ME
Cooling capacity* (kW)	44.8	50.4	56.0	84.0
Cooling capacity* (kW)	40.6	45.5	50.4	75.6
Heating capacity (kW)	50.0	56.5	63.0	94.5
No's of connectable Indoor units	27	30	33	50

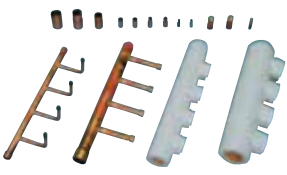
				
Capacity	32HP	34HP	38HP	40HP
Model Name (MMY-) 60 Hz	AP3226HT7P-ME	AP3426HT7P-ME	AP3826HT7P-ME	AP4026HT7P-ME
Units in combination (MMY-)	MAP1206HT7P-ME MAP1006HT7P-ME MAP1006HT7P-ME	MAP1206HT7P-ME MAP1206HT7P-ME MAP1006HT7P-ME	MAP1406HT7P-ME MAP1206HT7P-ME MAP1206HT7P-ME	MAP1406HT7P-ME MAP1406HT7P-ME MAP1206HT7P-ME
Cooling capacity* (kW)	89.5	95.0	107.0	113.5
Cooling capacity* (kW)	77.2	78.8	86.1	91.8
Heating capacity (kW)	100.5	106.5	120.0	127.5
No's of connectable Indoor units	54	57	64	64

	Y-shape branching joint				Branch headers				Outdoor unit connection piping kit	
Appearance										
Model name	RBM - BY55E	RBM - BY105E	RBM - BY205E	RBM - BY305E	RBM - HY1043E	RBM - HY2043E	RBM - HY1083E	RBM - HY2083E	RBM-BT14E	RBM-BT24E
Usage (Classification according to indoor unit capacity code)	Total below 6.4	Total 6.4 or more and below 14.2	Total 14.2 or more and below 25.2	Total 25.2 or more	Max.4 branches		Max.8 branches		Total below 26.0	Total 26.0 or more
					Total below 14.2	Total 14.2 or more and below 25.2	Total below 14.2	Total 14.2 or more and below 25.2		

* Power: 3phase 4wires 60Hz 380V

* The source voltage must not fluctuate more than 10%.

* Rated conditions

* Cooling: Indoor air temperature 26.7°C DB/19.4°C WB, outdoor air temperature 35°C DB (AHRI 1230 standard)

* Cooling: Indoor air temperature 26.7°C DB/19.4°C WB, outdoor air temperature 46°C DB (AHRI 1230 standard)

Heating: Indoor air temperature 20°C DB, outdoor air temperature 7°C DB/6°C WB

Outdoor unit specifications

Standard model (Single unit)

Technical specifications

Equivalent HP				8HP	10HP	12HP
Model name	Heat Pump	60Hz	(MMY-)	MAP0806HT7P-ME	MAP1006HT7P-ME	MAP1206HT7P-ME
Outdoor unit type				Inverter		
Power supply (*1)				3phase 4wires 60Hz 380V		
Cooling (*)	Capacity 100%		(kW)	22.4	28.0	33.5
	Power consumption		(kW)	4.84	6.28	8.24
	EER (Energy efficiency ratio)			4.63	4.46	4.07
Cooling (**)	Capacity 100%		(kW)	20.3	25.2	26.8
	Power consumption		(kW)	6.54	8.75	8.98
	EER (Energy efficiency ratio)			3.10	2.88	2.98
Heating (*2)	Capacity 100%		(kW)	25.0	31.5	37.5
	Power consumption		(kW)	5.38	7.08	9.24
	COP (Coefficient of performance)			4.65	4.45	4.06
Starting Current				Soft Start		
External dimensions (Height / Width / Depth)				(mm) 1,800 / 990 / 780		
Total weight	Heat Pump		(kg)	242	242	242
Compressor	Quantity		(nos)	2	2	2
Fan unit	Air volume		(m / h)	9,700	9,700	12,200
Refrigerant R410A (Charged refrigerant amount)				(kg) 11.5		
Refrigerant piping	Main pipe diameter	Gas side	(mm)	Φ19.1	Φ22.2	Φ28.6
		Liquid side	(mm)	Φ12.7	Φ12.7	Φ12.7
		Balance pipe	(mm)	Φ9.5	Φ9.5	Φ9.5
Sound pressure level (Cooling/Heating)				(dB(A)) 55 / 56		
Sound power level (Cooling/Heating)				(dB(A)) 74 / 74		
Connectable indoor units				(nos) 13		

Standard model (Single unit)

Technical specifications

Equivalent HP				14HP	16HP	18HP	20HP
Model name	Heat Pump	60Hz	(MMY-)	MAP1406HT7P-ME	MAP1606HT7P-ME	MAP1806HT7P-ME	MAP2006HT7P-ME
Outdoor unit type				Inverter			
Power supply (*1)				3phase 4wires 60Hz 380V			
Cooling (*)	Capacity 100%		(kW)	40.0	45.0	50.4	56.0
	Power consumption		(kW)	9.86	12.1	12.3	15.5
	EER (Energy efficiency ratio)			4.05	3.72	4.10	3.61
Cooling (**)	Capacity 100%		(kW)	32.5	36.0	42.8	44.8
	Power consumption		(kW)	11.6	12.5	14.2	14.9
	EER (Energy efficiency ratio)			2.80	2.88	3.01	3.01
Heating (*2)	Capacity 100%		(kW)	45.0	50.0	56.0	63.0
	Power consumption		(kW)	10.6	12.5	13.6	16.5
	COP (Coefficient of performance)			4.25	4.00	4.12	3.82
Starting Current				Soft Start			
External dimensions (Height / Width / Depth)				(mm) 1,800 / 1,210 / 780			
Total weight	Heat Pump		(kg)	299	299	370	370
Compressor	Quantity		(nos)	2	2	2	2
Fan unit	Air volume		(m / h)	12,200	12,600	17,300	17,900
Refrigerant R410A (Charged refrigerant amount)				(kg) 11.5			
Refrigerant piping	Main pipe diameter	Gas side	(mm)	Φ28.6	Φ28.6	Φ28.6	Φ28.6
		Liquid side	(mm)	Φ15.9	Φ15.9	Φ15.9	Φ15.9
		Balance pipe	(mm)	Φ9.5	Φ9.5	Φ9.5	Φ9.5
Sound pressure level (Cooling/Heating)				(dB(A)) 60 / 62			
Sound power level (Cooling/Heating)				(dB(A)) 80 / 82			
Connectable indoor units				(nos) 23			

Protective devices: Discharge temp. sensor / Suction temp. sensor / High-pressure sensor Low-pressure sensor / High-pressure switch / PC board fuse

*1 The source voltage must not flucture more than 10%.

* Indoor temperature: 26.7°C DB/19.4°CWB, outdoor temperature: 35°C DB (AHRI 1230 standard).

** Indoor temperature: 26.7°C DB/19.4°CWB, outdoor temperature: 46°C DB (AHRI 1230 standard).

*2 Heating : Indoor air temperature 20°C DB, Outdoor air temperature 7°C DB/6°C WB

Outdoor unit specifications

Standard model (Combination)

Technical specifications

Equivalent HP				22HP		24HP		26HP	
Model name	Heat Pump	60Hz	(MMY-)	MAP2216HT7P-ME		MAP2416HT7P-ME		MAP2616HT7P-ME	
Outdoor unit type				Inverter					
Power supply (*1)				3phase 4wires 60Hz 380V					
Outdoor unit model	Heat Pump	60Hz	(MMY-)	MAP1206HT7P-ME	MAP1006HT7P-ME	MAP1206HT7P-ME	MAP1206HT7P-ME	MAP1406HT7P-ME	MAP1206HT7P-ME
Cooling (*)	Capacity 100%		(kW)	61.5		67.0		73.5	
	Power consumption		(kW)	14.5		16.5		18.1	
	EER (Energy efficiency ratio)			4.24		4.07		4.06	
Cooling (**)	Capacity 100%		(kW)	52.0		53.6		59.3	
	Power consumption		(kW)	17.73		17.96		20.6	
	EER (Energy efficiency ratio)			2.93		2.98		2.88	
Heating (*2)	Capacity 100%		(kW)	69.0		75.0		82.5	
	Power consumption		(kW)	16.3		18.5		19.8	
	COP (Coefficient of performance)			4.23		4.06		4.16	
Starting current				(A)		Soft start			
Total weight	Heat Pump		(kg)	242	242	242	242	299	242
Compressor	Quantity		(nos)	2	2	2	2	2	2
Fan unit	Air volume		(m /h)	12,200	9,700	12,200	12,200	12,200	12,200
Refrigerant R410A (Charged refrigerant amount)				(kg)		11.5	11.5	11.5	11.5
Refrigerant piping	Main pipe diameter	Gas side	(mm)	Φ28.6		Φ34.9		Φ34.9	
		Liquid side	(mm)	Φ19.1		Φ19.1		Φ19.1	
		Balance pipe	(mm)	Φ9.5		Φ9.5		Φ9.5	
Sound pressure level (Cooling/Heating)				(dB(A))		61.5/63		62/64	
Sound power level (Cooling/Heating)				(dB(A))		81/83		83/85	
Connectable indoor units				(nos)		37		40	

Standard model (Combination)

Technical specifications

Equivalent HP				28HP		30HP		32HP	
Model name	Heat Pump	60Hz	(MMY-)	AP2816HT7P-ME		AP3016HT7P-ME		AP3216HT7P-ME	
Outdoor unit type				Inverter					
Power supply (*1)				3phase 4wires 60Hz 380V					
Outdoor unit model	Heat Pump	60Hz	(MMY-)	MAP1406HT7P-ME	MAP1406HT7P-ME	MAP1606HT7P-ME	MAP1406HT7P-ME	MAP1606HT7P-ME	MAP1606HT7P-ME
Cooling (*)	Capacity 100%		(kW)	80.0		85.0		90.0	
	Power consumption		(kW)	19.7		22.0		24.2	
	EER (Energy efficiency ratio)			4.05		3.87		3.72	
Cooling (**)	Capacity 100%		(kW)	65.0		68.5		72.0	
	Power consumption		(kW)	23.2		24.1		25.0	
	EER (Energy efficiency ratio)			2.80		2.84		2.88	
Heating (*2)	Capacity 100%		(kW)	90.0		95.0		100.0	
	Power consumption		(kW)	21.2		23.1		25.0	
	COP (Coefficient of performance)			4.25		4.11		4.00	
Starting current				(A)		Soft start			
Total weight	Heat Pump		(kg)	299	299	299	299	299	299
Compressor	Quantity		(nos)	2	2	2	2	2	2
Fan unit	Air volume		(m /h)	12,200	12,200	12,600	12,200	12,600	12,600
Refrigerant R410A (Charged refrigerant amount)				(kg)		11.5	11.5	11.5	11.5
Refrigerant piping	Main pipe diameter	Gas side	(mm)	Φ34.9		Φ34.9		Φ34.9	
		Liquid side	(mm)	Φ19.1		Φ19.1		Φ19.1	
		Balance pipe	(mm)	Φ9.5		Φ9.5		Φ9.5	
Sound pressure level (Cooling/Heating)				(dB(A))		63/65		64.5/66.5	
Sound power level (Cooling/Heating)				(dB(A))		83/85		83.5/85.5	
Connectable indoor units				(nos)		47		50	

Protective devices: Discharge temp. sensor / Suction temp. sensor / High-pressure sensor Low-pressure sensor / High-pressure switch / PC board fuse

*1 The source voltage must not flucture more than 10%.

* Indoor temperature: 26.7°C DB/19.4°CWB, outdoor temperature: 35°C DB (AHRI 1230 standard).

** Indoor temperature: 26.7°C DB/19.4°CWB, outdoor temperature: 46°C DB (AHRI 1230 standard).

*2 Heating : Indoor air temperature 20°C DB, Outdoor air temperature 7°C DB/6°C WB

Outdoor unit specifications

Standard model (Combination)				Technical specifications					
Equivalent HP				34HP		36HP		38HP	
Model name	Heat Pump	60Hz	(MMY-)	AP3416HT7P-ME		AP3616HT7P-ME		AP3816HT7P-ME	
Outdoor unit type				Inverter					
Power supply (*1)				3phase 4wires 60Hz 380V					
Outdoor unit model	Heat Pump	60Hz	(MMY-)	MAP1806HT7P-ME	MAP1606HT7P-ME	MAP1806HT7P-ME	MAP1806HT7P-ME	MAP2006HT7P-ME	MAP1806HT7P-ME
Cooling (*)	Capacity 100%		(kW)	95.4		100.8		106.4	
	Power consumption		(kW)	24.4		24.6		27.8	
	EER (Energy efficiency ratio)			3.91		4.10		3.83	
Cooling (**)	Capacity 100%		(kW)	78.8		85.6		87.6	
	Power consumption		(kW)	26.7		28.4		29.1	
	EER (Energy efficiency ratio)			2.95		3.01		3.01	
Heating (*2)	Capacity 100%		(kW)	106.0		112.0		119.0	
	Power consumption		(kW)	26.1		27.2		30.1	
	COP (Coefficient of performance)			4.06		4.12		3.95	
Starting current				(A) Soft start					
Total weight	Heat Pump		(kg)	370	299	370	370	370	370
Compressor	Quantity		(nos)	2	2	2	2	2	2
Fan unit	Air volume		(m /h)	17,300	12,600	17,300	17,300	17,900	17,300
Refrigerant R410A (Charged refrigerant amount)				(kg)		11.5	11.5	11.5	11.5
Refrigerant piping	Main pipe diameter	Gas side	(mm)	Φ34.9		Φ41.3		Φ41.3	
		Liquid side	(mm)	Φ19.1		Φ22.2		Φ22.2	
		Balance pipe	(mm)	Φ9.5		Φ9.5		Φ9.5	
Sound pressure level (Cooling/Heating)				(dB(A))		64.5/66		63/64	
Sound power level (Cooling/Heating)				(dB(A))		84/86		84/86	
Connectable indoor units				(nos)		57		60	

Standard model (Combination)				Technical specifications					
Equivalent HP				40HP		42HP		44HP	
Model name	Heat Pump	60Hz	(MMY-)	AP4016HT7P-ME		AP4216HT7P-ME		AP4416HT7P-ME	
Outdoor unit type				Inverter					
Power supply (*1)				3phase 4wires 60Hz 380V					
Outdoor unit model	Heat Pump	60Hz	(MMY-)	MAP2006HT7P-ME	MAP2006HT7P-ME	MAP1406HT7P-ME	MAP1406HT7P-ME	MAP1406HT7P-ME	MAP1406HT7P-ME
Cooling (*)	Capacity 100%		(kW)	112.0		120.0		125.0	
	Power consumption		(kW)	31.0		29.6		31.8	
	EER (Energy efficiency ratio)			3.61		4.05		3.93	
Cooling (**)	Capacity 100%		(kW)	89.6		97.5		101.0	
	Power consumption		(kW)	29.8		34.8		35.7	
	EER (Energy efficiency ratio)			3.01		2.80		2.83	
Heating (*2)	Capacity 100%		(kW)	126.0		135.0		140.0	
	Power consumption		(kW)	33.0		31.8		33.7	
	COP (Coefficient of performance)			3.82		4.25		4.15	
Starting current				(A) Soft start					
Total weight	Heat Pump		(kg)	370	370	299	299	299	299
Compressor	Quantity		(nos)	2	2	2	2	2	2
Fan unit	Air volume		(m /h)	17,900	17,900	12,200	12,200	12,200	12,200
Refrigerant R410A (Charged refrigerant amount)				(kg)		11.5	11.5	11.5	11.5
Refrigerant piping	Main pipe diameter	Gas side	(mm)	Φ41.3		Φ41.3		Φ41.3	
		Liquid side	(mm)	Φ22.2		Φ22.2		Φ22.2	
		Balance pipe	(mm)	Φ9.5		Φ9.5		Φ9.5	
Sound pressure level (Cooling/Heating)				(dB(A))		64.0/65.0		65/67	
Sound power level (Cooling/Heating)				(dB(A))		85/87		85/87	
Connectable indoor units				(nos)		64		64	

Protective devices: Discharge temp. sensor / Suction temp. sensor / High-pressure sensor Low-pressure sensor / High-pressure switch / PC board fuse

*1 The source voltage must not fluctuate more than 10%.

* Indoor temperature: 26.7°C DB/19.4°CWB, outdoor temperature: 35°C DB (AHRI 1230 standard).

** Indoor temperature: 26.7°C DB/19.4°CWB, outdoor temperature: 46°C DB (AHRI 1230 standard).

*2 Heating : Indoor air temperature 20°C DB, Outdoor air temperature 7°C DB/6°C WB

Outdoor unit specifications

Standard model (Combination)				Technical specifications								
Equivalent HP				46HP			48HP			50HP		
Model name	Heat Pump	60Hz	(MMY-)	AP4616HT7P-ME			AP4816HT7P-ME			AP5016HT7P-ME		
Outdoor unit type				Inverter								
Power supply (*1)				3phase 4wires 60Hz 380V								
Outdoor unit model	Heat Pump	60Hz	(MMY-)	MAP1606HT7P-ME	MAP1606HT7P-ME	MAP1406HT7P-ME	MAP1606HT7P-ME	MAP1606HT7P-ME	MAP1606HT7P-ME	MAP1806HT7P-ME	MAP1606HT7P-ME	MAP1606HT7P-ME
Cooling (*)	Capacity 100%		(kW)	130.0			135.0			140.4		
	Power consumption		(kW)	34.1			36.3			36.5		
	EER (Energy efficiency ratio)			3.82			3.72			3.85		
Cooling (**)	Capacity 100%		(kW)	104.5			108.0			114.8		
	Power consumption		(kW)	36.6			37.5			39.2		
	EER (Energy efficiency ratio)			2.86			2.88			2.93		
Heating (*2)	Capacity 100%		(kW)	145.0			150.0			156.0		
	Power consumption		(kW)	35.6			37.5			38.6		
	COP (Coefficient of performance)			4.07			4.00			4.04		
Starting current				(A) Soft start								
Total weight	Heat Pump		(kg)	299	299	299	299	299	299	370	299	299
Compressor	Quantity		(nos)	2	2	2	2	2	2	2	2	2
Fan unit	Air volume		(m /h)	12,600	12,600	12,200	12,600	12,600	12,200	17,300	12,600	12,600
Refrigerant R410A (Charged refrigerant amount)				(kg)								
Refrigerant piping	Main pipe diameter	Gas side	(mm)	Φ41.3			Φ41.3			Φ41.3		
		Liquid side	(mm)	Φ22.2			Φ22.2			Φ22.2		
		Balance pipe	(mm)	Φ9.5			Φ9.5			Φ9.5		
Sound pressure level (Cooling/Heating)				(dB(A))								
Sound power level (Cooling/Heating)				(dB(A))								
Connectable indoor units				(nos)								

Standard model (Combination)				Technical specifications								
Equivalent HP				52HP			54HP			56HP		
Model name	Heat Pump	60Hz	(MMY-)	AP5216HT7P-ME			AP5416HT7P-ME			AP5616HT7P-ME		
Outdoor unit type				Inverter								
Power supply (*1)				3phase 4wires 60Hz 380V								
Outdoor unit model	Heat Pump	60Hz	(MMY-)	MAP1806HT7P-ME	MAP186HT7P-ME	MAP1606HT7P-ME	MAP2006HT7P-ME	MAP2006HT7P-ME	MAP1406HT7P-ME	MAP2006HT7P-ME	MAP2006HT7P-ME	MAP1606HT7P-ME
Cooling (*)	Capacity 100%		(kW)	145.8			152.0			157.0		
	Power consumption		(kW)	36.7			40.9			43.1		
	EER (Energy efficiency ratio)			3.97			3.72			3.64		
Cooling (**)	Capacity 100%		(kW)	121.6			122.1			125.6		
	Power consumption		(kW)	41.4			41.4			42.3		
	EER (Energy efficiency ratio)			2.97			2.95			2.97		
Heating (*2)	Capacity 100%		(kW)	162.0			171.0			176.0		
	Power consumption		(kW)	39.7			43.6			45.5		
	COP (Coefficient of performance)			4.08			3.92			3.87		
Starting current				(A) Soft start								
Total weight	Heat Pump		(kg)	370	370	299	370	370	299	370	370	299
Compressor	Quantity		(nos)	2	2	2	2	2	2	2	2	2
Fan unit	Air volume		(m /h)	17,300	17,300	12,600	17,900	17,900	12,200	17,900	17,900	12,600
Refrigerant R410A (Charged refrigerant amount)				(kg)								
Refrigerant piping	Main pipe diameter	Gas side	(mm)	Φ41.3			Φ41.3			Φ41.3		
		Liquid side	(mm)	Φ22.2			Φ22.2			Φ22.2		
		Balance pipe	(mm)	Φ9.5			Φ9.5			Φ9.5		
Sound pressure level (Cooling/Heating)				(dB(A))								
Sound power level (Cooling/Heating)				(dB(A))								
Connectable indoor units				(nos)								

Protective devices: Discharge temp. sensor / Suction temp. sensor / High-pressure sensor Low-pressure sensor / High-pressure switch / PC board fuse

*1 The source voltage must not flucture more than 10%.

* Indoor temperature: 26.7°C DB/19.4°CWB, outdoor temperature: 35°C DB (AHRI 1230 standard).

** Indoor temperature: 26.7°C DB/19.4°CWB, outdoor temperature: 46°C DB (AHRI 1230 standard).

*2 Heating : Indoor air temperature 20°C DB, Outdoor air temperature 7°C DB/6°C WB

Outdoor unit specifications

High efficiency model (Combination)

Technical specifications

Equivalent HP				16HP		18HP	
Model name	Heat Pump	60Hz	(MMY-)	AP1626HT7P-ME		AP1826HT7P-ME	
Outdoor unit type				Inverter			
Power supply (*1)				3phase 4wires 60Hz 380V			
Outdoor unit model	Heat Pump	60Hz	(MMY-)	MAP0806HT7P-ME	MAP0806HT7P-ME	MAP1006HT7P-ME	MAP0806HT7P-ME
Cooling (*)	Capacity 100%		(kW)	44.8		50.4	
	Power consumption		(kW)	9.68		11.1	
	EER (Energy efficiency ratio)			4.63		4.53	
Cooling (**)	Capacity 100%		(kW)	40.6		45.5	
	Power consumption		(kW)	13.1		15.3	
	EER (Energy efficiency ratio)			3.10		2.98	
Heating (*2)	Capacity 100%		(kW)	50.0		56.5	
	Power consumption		(kW)	10.76		12.5	
	COP (Coefficient of performance)			4.65		4.53	
Starting current			(A)	Soft start			
Total weight	Heat Pump		(kg)	242	242	242	242
Compressor	Quantity		(nos)	2	2	2	2
Fan unit	Air volume		(m /h)	9,700	9,700	9,700	9,700
Refrigerant R410A (Charged refrigerant amount)			(kg)	11.5	11.5	11.5	11.5
Refrigerant piping	Main pipe diameter	Gas side	(mm)	Φ28.6		Φ28.6	
		Liquid side	(mm)	Φ15.9		Φ15.9	
		Balance pipe	(mm)	Φ9.5		Φ9.5	
Sound pressure level (Cooling/Heating)			(dB(A))	58 / 59		59.5 / 60.5	
Sound power level (Cooling/Heating)			(dB(A))	77 / 77		77 / 77	
Connectable indoor units			(nos)	27		30	

High efficiency model (Combination)

Technical specifications

Equivalent HP				20HP		30HP		
Model name	Heat Pump	60Hz	(MMY-)	AP2026HT7P-ME		AP3026HT7P-ME		
Outdoor unit type				Inverter				
Power supply (*1)				3phase 4wires 60Hz 380V				
Outdoor unit model	Heat Pump	60Hz	(MMY-)	MAP1006HT7P-ME	MAP1006HT7P-ME	MAP1006HT7P-ME	MAP1006HT7P-ME	MAP1006HT7P-ME
Cooling (*)	Capacity 100%		(kW)	56.0		84.0		
	Power consumption		(kW)	12.6		18.8		
	EER (Energy efficiency ratio)			4.46		4.46		
Cooling (**)	Capacity 100%		(kW)	50.4		75.6		
	Power consumption		(kW)	17.5		26.3		
	EER (Energy efficiency ratio)			2.88		2.88		
Heating (*2)	Capacity 100%		(kW)	63.0		94.5		
	Power consumption		(kW)	14.2		21.2		
	COP (Coefficient of performance)			4.45		4.45		
Starting current			(A)	Soft start				
Total weight	Heat Pump		(kg)	242	242	242	242	242
Compressor	Quantity		(nos)	2	2	2	2	2
Fan unit	Air volume		(m /h)	9,700	9,700	9,700	9,700	9,700
Refrigerant R410A (Charged refrigerant amount)			(kg)	11.5	11.5	11.5	11.5	11.5
Refrigerant piping	Main pipe diameter	Gas side	(mm)	Φ28.6		Φ34.9		
		Liquid side	(mm)	Φ15.9		Φ19.1		
		Balance pipe	(mm)	Φ9.5		Φ9.5		
Sound pressure level (Cooling/Heating)			(dB(A))	60 / 61		62 / 63		
Sound power level (Cooling/Heating)			(dB(A))	77 / 77		79 / 79		
Connectable indoor units			(nos)	33		50		

Protective devices: Discharge temp. sensor / Suction temp. sensor / High-pressure sensor Low-pressure sensor / High-pressure switch / PC board fuse

*1 The source voltage must not flucture more than 10%.

* Indoor temperature: 26.7°C DB/19.4°CWB, outdoor temperature: 35°C DB (AHRI 1230 standard).

** Indoor temperature: 26.7°C DB/19.4°CWB, outdoor temperature: 46°C DB (AHRI 1230 standard).

*2 Heating : Indoor air temperature 20°C DB, Outdoor air temperature 7°C DB/6°C WB

Outdoor unit specifications

High efficiency model (Combination)

Technical specifications

Equivalent HP				32HP			34HP		
Model name	Heat Pump	60Hz	(MMY-)	AP3226HT7P-ME			AP3426HT7P-ME		
Outdoor unit type				Inverter					
Power supply (*1)				3phase 4wires 60Hz 380V					
Outdoor unit model	Heat Pump	60Hz	(MMY-)	MAP1206HT7P-ME	MAP1006HT7P-ME	MAP1006HT7P-ME	MAP1206HT7P-ME	MAP1206HT7P-ME	MAP1006HT7P-ME
Cooling (*)	Capacity 100%		(kW)	89.5			95.0		
	Power consumption		(kW)	20.8			22.8		
	EER (Energy efficiency ratio)			4.30			4.17		
Cooling (**)	Capacity 100%		(kW)	77.2			78.8		
	Power consumption		(kW)	26.5			26.7		
	EER (Energy efficiency ratio)			2.92			2.95		
Heating (*2)	Capacity 100%		(kW)	100.5			106.5		
	Power consumption		(kW)	23.4			25.6		
	COP (Coefficient of performance)			4.29			4.17		
Starting current				(A) Soft start					
Total weight	Heat Pump		(kg)	242	242	242	242	242	242
Compressor	Quantity		(nos)	2	2	2	2	2	2
Fan unit	Air volume		(m /h)	12,200	9,700	9,700	12,200	12,200	9,700
Refrigerant R410A (Charged refrigerant amount)				(kg)					
Refrigerant piping	Main pipe diameter	Gas side	(mm)	Φ34.9			Φ34.9		
		Liquid side	(mm)	Φ19.1			Φ19.1		
		Balance pipe	(mm)	Φ9.5			Φ9.5		
Sound pressure level (Cooling/Heating)				(dB(A))					
Sound power level (Cooling/Heating)				(dB(A))					
Connectable indoor units				(nos)					

High efficiency model (Combination)

Technical specifications

Equivalent HP				38HP			40HP		
Model name	Heat Pump	60Hz	(MMY-)	AP3826HT7P-ME			AP4026HT7P-ME		
Outdoor unit type				Inverter					
Power supply (*1)				3phase 4wires 60Hz 380V					
Outdoor unit model	Heat Pump	60Hz	(MMY-)	MAP1406HT7P-ME	MAP1206HT7P-ME	MAP1206HT7P-ME	MAP1406HT7P-ME	MAP1406HT7P-ME	MAP1206HT7P-ME
Cooling (*)	Capacity 100%		(kW)	107.0			113.5		
	Power consumption		(kW)	26.3			28.0		
	EER (Energy efficiency ratio)			4.06			4.06		
Cooling (**)	Capacity 100%		(kW)	86.1			91.8		
	Power consumption		(kW)	29.6			32.2		
	EER (Energy efficiency ratio)			2.91			2.85		
Heating (*2)	Capacity 100%		(kW)	120.0			127.5		
	Power consumption		(kW)	29.1			30.4		
	COP (Coefficient of performance)			4.13			4.19		
Starting current				(A) Soft start					
Total weight	Heat Pump		(kg)	299	242	242	299	299	242
Compressor	Quantity		(nos)	2	2	2	2	2	2
Fan unit	Air volume		(m /h)	12,200	12,200	12,200	12,200	12,200	12,200
Refrigerant R410A (Charged refrigerant amount)				(kg)					
Refrigerant piping	Main pipe diameter	Gas side	(mm)	Φ41.3			Φ41.3		
		Liquid side	(mm)	Φ22.2			Φ22.5		
		Balance pipe	(mm)	Φ9.5			Φ9.5		
Sound pressure level (Cooling/Heating)				(dB(A))					
Sound power level (Cooling/Heating)				(dB(A))					
Connectable indoor units				(nos)					

Protective devices: Discharge temp. sensor / Suction temp. sensor / High-pressure sensor Low-pressure sensor / High-pressure switch / PC board fuse

*1 The source voltage must not flucture more than 10%.

* Indoor temperature: 26.7°C DB/19.4°CWB, outdoor temperature: 35°C DB (AHRI 1230 standard).

** Indoor temperature: 26.7°C DB/19.4°CWB, outdoor temperature: 46°C DB (AHRI 1230 standard).

*2 Heating : Indoor air temperature 20°C DB, Outdoor air temperature 7°C DB/6°C WB

Model: MMY-MAP0806HT7P-ME
 MMY-MAP1006HT7P-ME
 MMY-MAP1206HT7P-ME

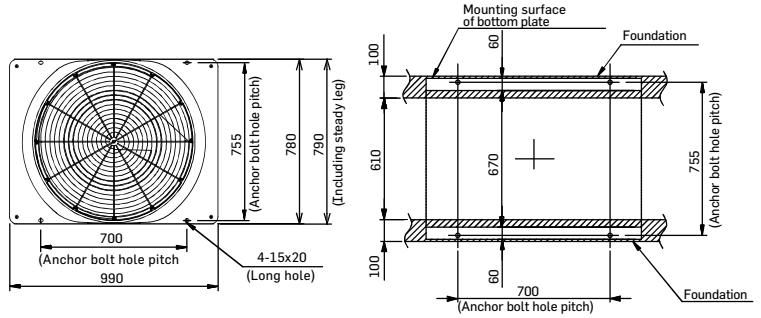

Note:

1. If there is an obstacle at the upper side of the outdoor unit, set the top end of the outdoor unit 2000mm apart from the obstacle.
2. Limit the height of the obstacle surrounding the outdoor unit to 800mm or less from the bottom end of the outdoor unit.
3. Draw out the pipe procured locally to the front of the outdoor unit horizontally and keep 500mm or more between the outdoor unit and traversing pipe if placing pipe transversely.
4. Dimensional drawing of corrosion heavy protection model is the same as that of standard model.

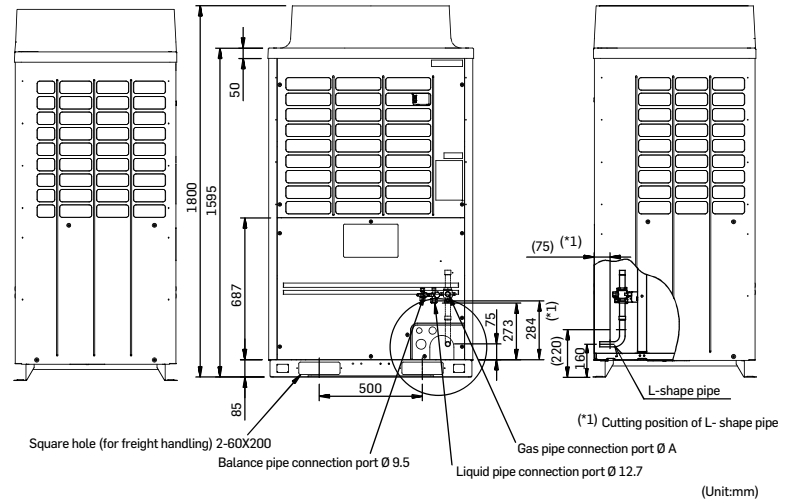

(Unit:mm)

Model: MMY-MAP1406HT7P-ME
 MMY-MAP1606HT7P-ME

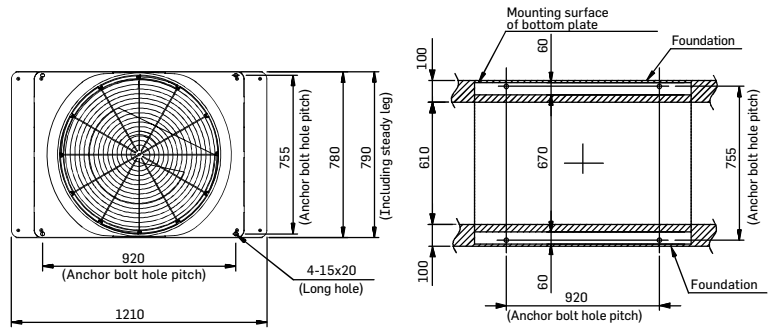

Note:

1. If there is an obstacle at the upper side of the outdoor unit, set the top end of the outdoor unit 2000mm apart from the obstacle.
2. Limit the height of the obstacle surrounding the outdoor unit to 800mm or less from the bottom end of the outdoor unit.
3. Draw out the pipe procured locally to the front of the outdoor unit horizontally and keep 500mm or more between the outdoor unit and traversing pipe if placing pipe transversely.
4. Dimensional drawing of corrosion heavy protection model is the same as that of standard model.

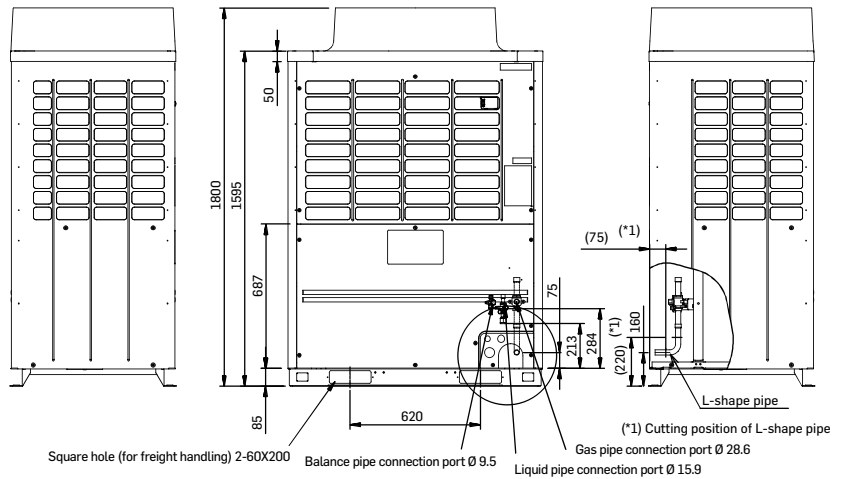

(Unit:mm)

Model: MMY-MAP1806HT7P-ME
MMY-MAP2006HT7P-ME

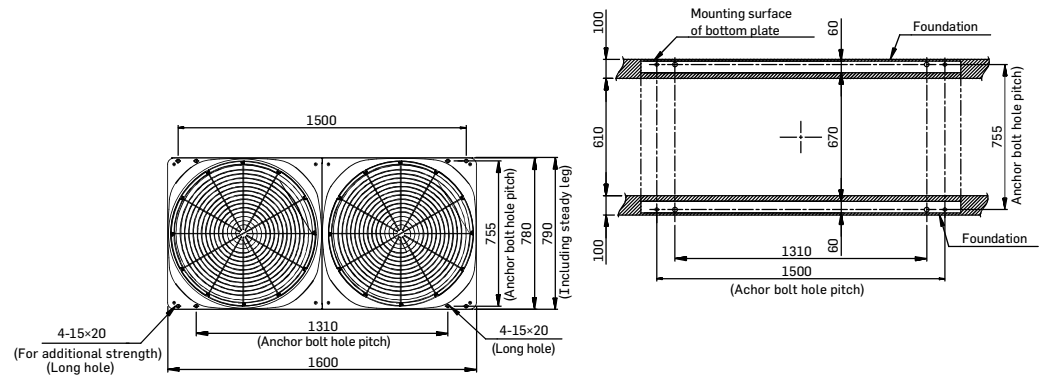

Note:

1. If there is an obstacle at the upper side of the outdoor unit, set the top end of the outdoor unit 2000mm apart from the obstacle.
2. Limit the height of the obstacle surrounding the outdoor unit to 800mm or less from the bottom end of the outdoor unit.
3. Draw out the pipe procured locally to the front of the outdoor unit horizontally and keep 500mm or more between the outdoor unit and traversing pipe if placing pipe transversely.
4. Dimensional drawing of corrosion heavy protection model is the same as that of standard model.

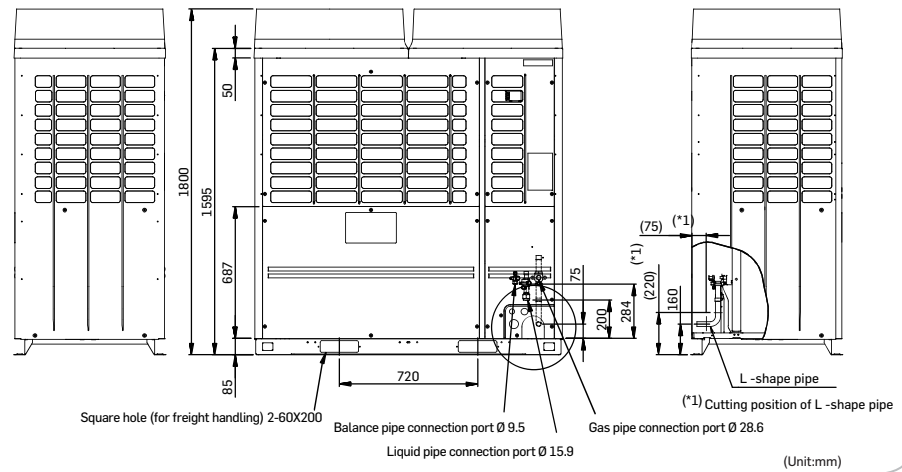

(Unit:mm)



Indoor units line-up



Cooling capacity (HP equivalent)	4-way air discharge cassette type	Compact 4-way cassette (620 x 620) type	2-way air discharge cassette type	1-way air discharge cassette type	Concealed duct type
007 type 2.2 kW (0.8HP)		MMU-AP0077MH-E	MMU-AP0072WH1	MMU-AP0074YH1-E	MMD-AP0076BHP1-E
009 type 2.8 kW (1HP)	MMU-AP0094HP1-E	MMU-AP0097MH-E	MMU-AP0092WH1	MMU-AP0094YH1-E	MMD-AP0096BHP1-E
012 type 3.6 kW (1.25HP)	MMU-AP0124HP1-E	MMU-AP0127MH-E	MMU-AP0122WH1	MMU-AP0124YH1-E	MMD-AP0126BHP1-E
015 type 4.5 kW (1.7HP)	MMU-AP0154HP1-E	MMU-AP0157MH-E	MMU-AP0152WH1	MMU-AP0154SH1-E	MMD-AP0156BHP1-E
018 type 5.6 kW (2HP)	MMU-AP0184HP1-E	MMU-AP0187MH-E	MMU-AP0182WH1	MMU-AP0184SH1-E	MMD-AP0186BHP1-E
024 type 7.1 kW (2.5HP)	MMU-AP0244HP1-E		MMU-AP0242WH1	MMU-AP0244SH1-E	MMD-AP0246BHP1-E
027 type 8.0 kW (3HP)	MMU-AP0274HP1-E		MMU-AP0272WH1		MMD-AP0276BHP1-E
030 type 9.0 kW (3.2HP)	MMU-AP0304HP1-E		MMU-AP0302WH1		MMD-AP0306BHP1-E
036 type 11.2 kW (4HP)	MMU-AP0364HP1-E		MMU-AP0362WH1		MMD-AP0366BHP1-E
048 type 14.0 kW (5HP)	MMU-AP0484HP1-E		MMU-AP0482WH1		MMD-AP0486BHP1-E
056 type 16.0 kW (6HP)	MMU-AP0564HP1-E		MMU-AP0562WH1		MMD-AP0566BHP1-E
072 type 22.4 kW (8HP)					
096 type 28.0 kW (10HP)					



Cooling capacity (HP equivalent)	Concealed duct high static pressure type	Slim duct type	Ceiling type	High wall type 7 series	Console
007 type 2.2 kW (0.8HP)		MMD-AP0074SPH1-E		MMK-AP0077HP-E	MML-AP0074NH1-E
009 type 2.8 kW (1HP)		MMD-AP0094SPH1-E		MMK-AP0097HP-E	MML-AP0094NH1-E
012 type 3.6 kW (1.25HP)		MMD-AP0124SPH1-E		MMK-AP0127HP-E	MML-AP0124NH1-E
015 type 4.5 kW (1.7HP)		MMD-AP0154SPH1-E	MMC-AP0158HP-E	MMK-AP0157HP-E	MML-AP0154NH1-E
018 type 5.6 kW (2HP)	MMD-AP0186HP1-E	MMD-AP0184SPH1-E	MMC-AP0188HP-E	MMK-AP0187HP-E	MML-AP0184NH1-E
024 type 7.1 kW (2.5HP)	MMD-AP0246HP1-E	MMD-AP0244SPH1-E	MMC-AP0248HP-E	MMK-AP0247HP-E	
027 type 8.0 kW (3HP)	MMD-AP0276HP1-E	MMD-AP0274SPH1-E	MMC-AP0278HP-E		
030 type 9.0 kW (3.2HP)					
036 type 11.2 kW (4HP)	MMD-AP0366HP1-E		MMC-AP0368HP-E		
048 type 14.0 kW (5HP)	MMD-AP0486HP1-E		MMC-AP0488HP-E		
056 type 16.0 kW (6HP)	MMD-AP0566HP1-E		MMC-AP0568HP-E		
072 type 22.4 kW (8HP)	MMD-AP0726HP-E				
096 type 28.0 kW (10HP)	MMD-AP0966HP-E				



Cooling capacity (HP equivalent)	Floor standing cabinet type	Floor standing concealed type	Floor standing type	Fresh air intake indoor unit type
007 type 2.2 kW (0.8 HP)	MML-AP0074H1-E	MML-AP0074BH1-E		
009 type 2.8 kW (1.0 HP)	MML-AP0094H1-E	MML-AP0094BH1-E		
012 type 3.6 kW (1.25 HP)	MML-AP0124H1-E	MML-AP0124BH1-E		
015 type 4.5 kW (1.7 HP)	MML-AP0154H1-E	MML-AP0154BH1-E	MMF-AP0156H1-E	
018 type 5.6 kW (2.0 HP)	MML-AP0184H1-E	MML-AP0184BH1-E	MMF-AP0186H1-E	
024 type 7.1 kW (2.5 HP)	MML-AP0244H1-E	MML-AP0244BH1-E	MMF-AP0246H1-E	
027 type 8.0 kW (3.0 HP)			MMF-AP0276H1-E	
030 type 9.0 kW (3.2 HP)				
036 type 11.2 kW (4.0 HP)			MMF-AP0366H1-E	
048 type 14.0 kW (5.0 HP)			MMF-AP0486H1-E	MMD-AP0481HFE
056 type 16.0 kW (6.0 HP)			MMF-AP0566H1-E	
072 type 22.4 kW (8.0 HP)				MMD-AP0721HFE
096 type 28.0 kW (10.0 HP)				MMD-AP0961HFE



4-way air discharge cassette type

MMU-AP***4HP1-E

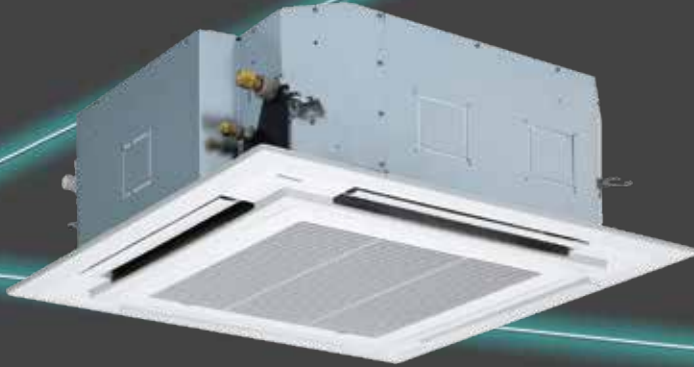

Individual louver control

The angles of each of the four louvers can be set individually. This enables airflow to be adapted to user preferences.

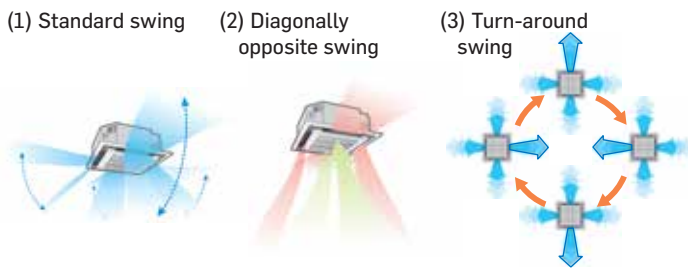

Note: RBC-AMT32E, RBC-AMTU31-E, RBC-AMS41E only

Easy installation

The panel is attached using the bolt already installed on the indoor unit.



RBC-U31PGP(W)-E

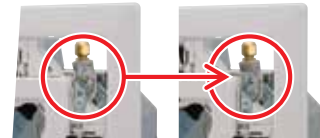

Remote controller



RBC-AX32U(W)-E



RBC-ASC11E
RBC-ASC11UE



RBC-AMS55E-EN/ES
RBC-AMSU51-EN/ES

Technical specifications

Model name	MMU-	AP0074HP-ME	AP0094HP1-E	AP0124HP1-E/HP-ME	AP0154HP1-E	AP0184HP1-E/HP-ME	AP0244HP1-E	AP0274HP1-E	AP0304HP1-E	AP0364HP1-E	AP0484HP1-E	AP0564HP1-E						
Cooling/Heating capacity*1	(kW)	2.2/2.5	2.8/3.2	3.6/4.0	4.5/5.0	5.6/6.3	7.1/8.0	8.0/9.0	9.0/10.0	11.2/12.5	14.0/16.0	16.0/18.0						
Electrical characteristics	Power requirements	1-phase 50Hz 230V (220-240V) / 1-phase 60Hz 220V (Separate power supply for indoor units required.)																
	Power consumption 50 Hz/60 Hz	(kW)	0.021/0.021		0.023/0.023		0.026/0.026		0.036/0.036		0.043/0.043		0.088/0.088		0.112/0.112		0.112/0.112	
Appearance (Ceiling panel)	Model	RBC-U31PGP(W)-E / RBC-U31PGXP(W)-IN1																
External dimensions: Main unit (Ceiling panel)*	Height	256 (30)*									319 (30)*							
	Width	840 (950)*						840 (950)*										
	Depth	840 (950)*						840 (950)*										
Total weight: Main unit (Ceiling panel)*	(kg)	18 (4)*			20 (4)*				25 (4)*									
Fan unit	Standard air flow (High/Mid/Low)	800/730/680			930/830/790		1050/920/800		1290/920/800		1320/1110/850		1970/1430/1070		2130/1430/1130		2130/1520/1230	
	Motor output	14			14				20			68		72				
Connecting pipe	Gas side	ø9.5			ø12.7			ø15.9										
	Liquid side	ø6.4						ø9.5										
	Drain port (nominal dia.)	25 (Polyvinyl chloride tube)																
Sound pressure level*2 (High/Mid/Low)	(dB(A))	30/29/27			31/29/27		32/29/27		35/31/28		38/33/30		43/38/32		46/38/33		46/40/33	
Sound power level (High/Mid/Low)	(dB(A))	45/44/42			46/44/42		47/44/42		50/46/43		53/48/45		58/53/47		61/53/48		61/55/48	

* Figures in parentheses are for ceiling panels.

Note 1: The capacities are measured under the conditions specified by JIS B 8615 based on the reference piping.

Note 2: The sound level are measured in an anechoic chamber in accordance with JIS B 8616.

Normally, the values measured in the actual operating environment become larger than the indicated values due to the effects of external sound.

Note: Rated conditions Cooling: Indoor air temperature 27°C DB/19°C WB, Outdoor air temperature 35°C DB

Heating: Indoor air temperature 20°C DB, Outdoor air temperature 7°C DB/6°C WB

MMU- AP0074HP-ME, AP0094HP1-E to AP0564HP1-E

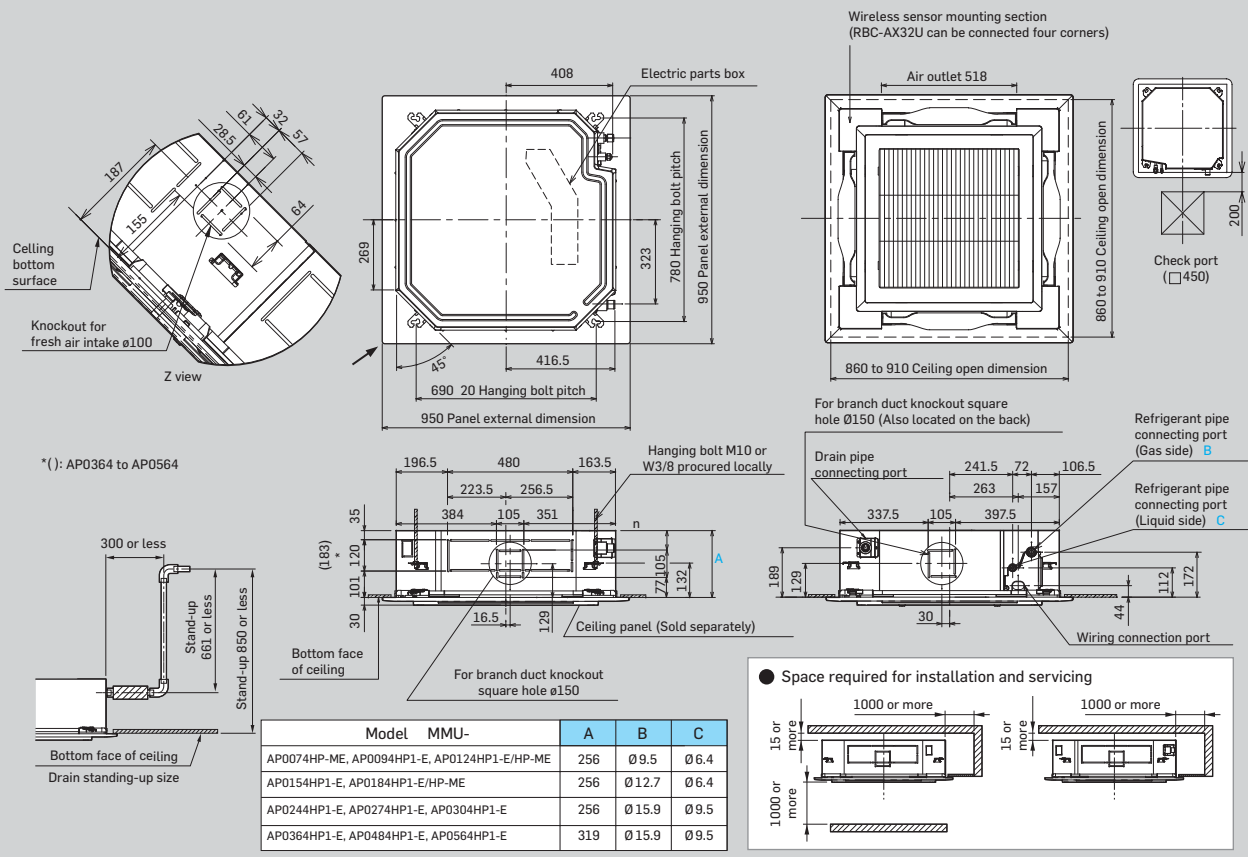

* The figure shows the RBC-U31PGP(W)-E panel

Options

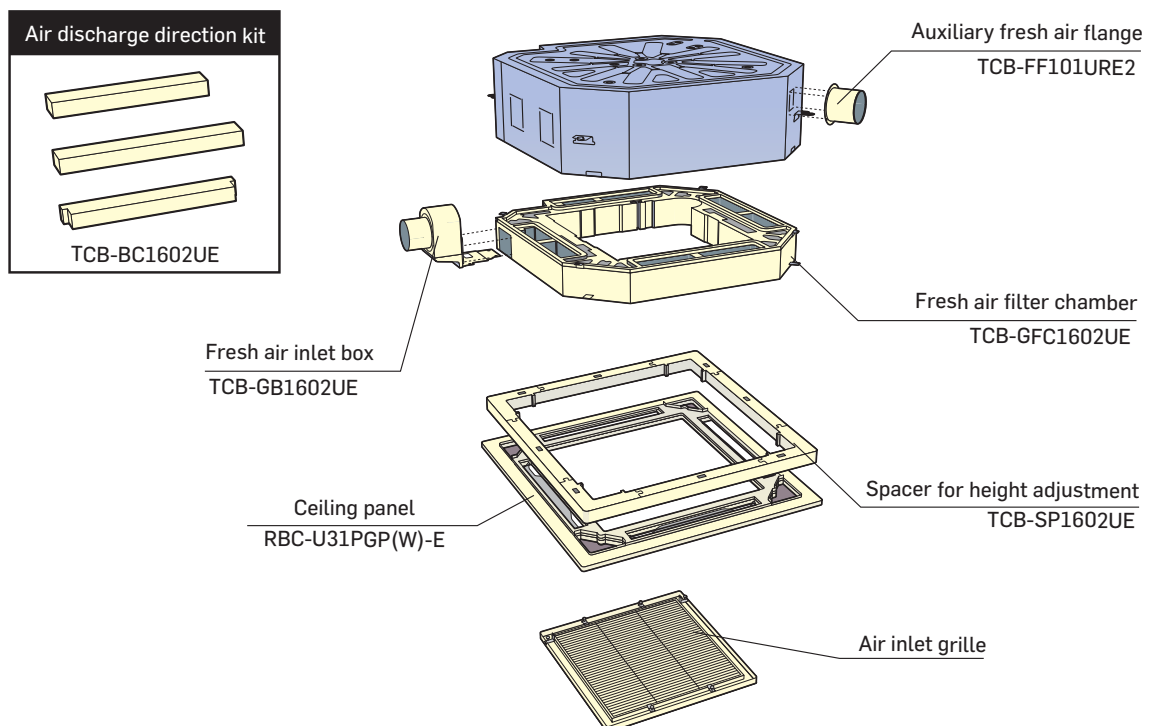



Perfect solution for grid ceiling system

This compact unit (575 × 575 mm) fits perfectly into ceilings and matches standard architectural modules, without the need to cut ceiling tiles. The flaps fold tightly against the ceiling when operation stops so that there is minimal affect on the ceiling due to air conditioning system installation.

Designed for simple & easy installation and maintenance

The slim design is only 256 mm in height even when an electrical box is located inside the unit. Easy installation is also possible using the panel adjust pocket. Use the "adjust pocket" function for fine adjustments after installation. Available for ceilings up to 3.5 m in height.



RBC-UM21PG(W)E

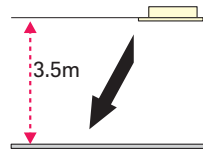

Maximum height

Remote controller



TCB-SIR41UM-E



RBC-AX32UM(W)-E



RBC-ASC11E
RBC-ASC11UE



RBC-AMS55E-EN/ES
RBC-AMSU51-EN/ES

Technical specifications

Model name		MMU-	AP0077MH-E	AP0097MH-E	AP0127MH-E	AP0157MH-E	AP0187MH-E
Cooling/Heating capacity*1		(kW)	2.2/2.5	2.8/3.2	3.6/4.0	4.5/5.0	5.6/6.3
Electrical characteristics	Power requirements	1-phase 50Hz 230V (220–240V) / 1-phase 60Hz 220V (Separate power supply for indoor units required.)					
	Power consumption 50 Hz/60 Hz	(kW)	0.023/0.023	0.025/0.025	0.027/0.027	0.030/0.030	0.052/0.052
Appearance (Ceiling panel)		Model	RBC-UM21PG(W)-E				
External dimensions: Main unit (Ceiling panel)*	Height	(mm)	256 (12)*				
	Width	(mm)	575 (620)*				
	Depth	(mm)	575 (620)*				
Total weight: Main unit (Ceiling panel)*		(kg)	17 (3)*				
Fan unit	Standard air flow (High/Mid/Low)	(m ³ /h)	552/462/378	570/468/378	594/504/402	660/552/468	840/642/522
	Motor output	(w)	60				
Connecting pipe	Gas side	(mm)	ø9.5			ø12.7	
	Liquid side	(mm)	ø6.4				
	Drain port (nominal dia.)	(mm)	VP20 (Polyvinyl chloride tube)				
Sound pressure level*2 (High/Mid/Low)		(dB(A))	37/33/29	38/33/29	38/34/30	40/35/31	47/39/34
Sound power level (High/Mid/Low)		(dB(A))	52/48/44	53/48/44	53/49/45	55/50/46	62/54/49

* Figures in parentheses are for ceiling panels.

Note 1 : The capacities are measured under the conditions specified by JIS B 8615 based on the reference piping.

Note 2 : The sound level are measured in an anechoic chamber in accordance with JIS B 8616.

Normally, the values measured in the actual operating environment become larger than the indicated values due to the effects of external sound.

Note : Rated conditions Cooling : Indoor air temperature 27°C DB/19°C WB, Outdoor air temperature 35°C DB

Heating : Indoor air temperature 20°C DB, Outdoor air temperature 7°C DB/6°C WB

MMU-AP0077MH-E to AP0187MH-E

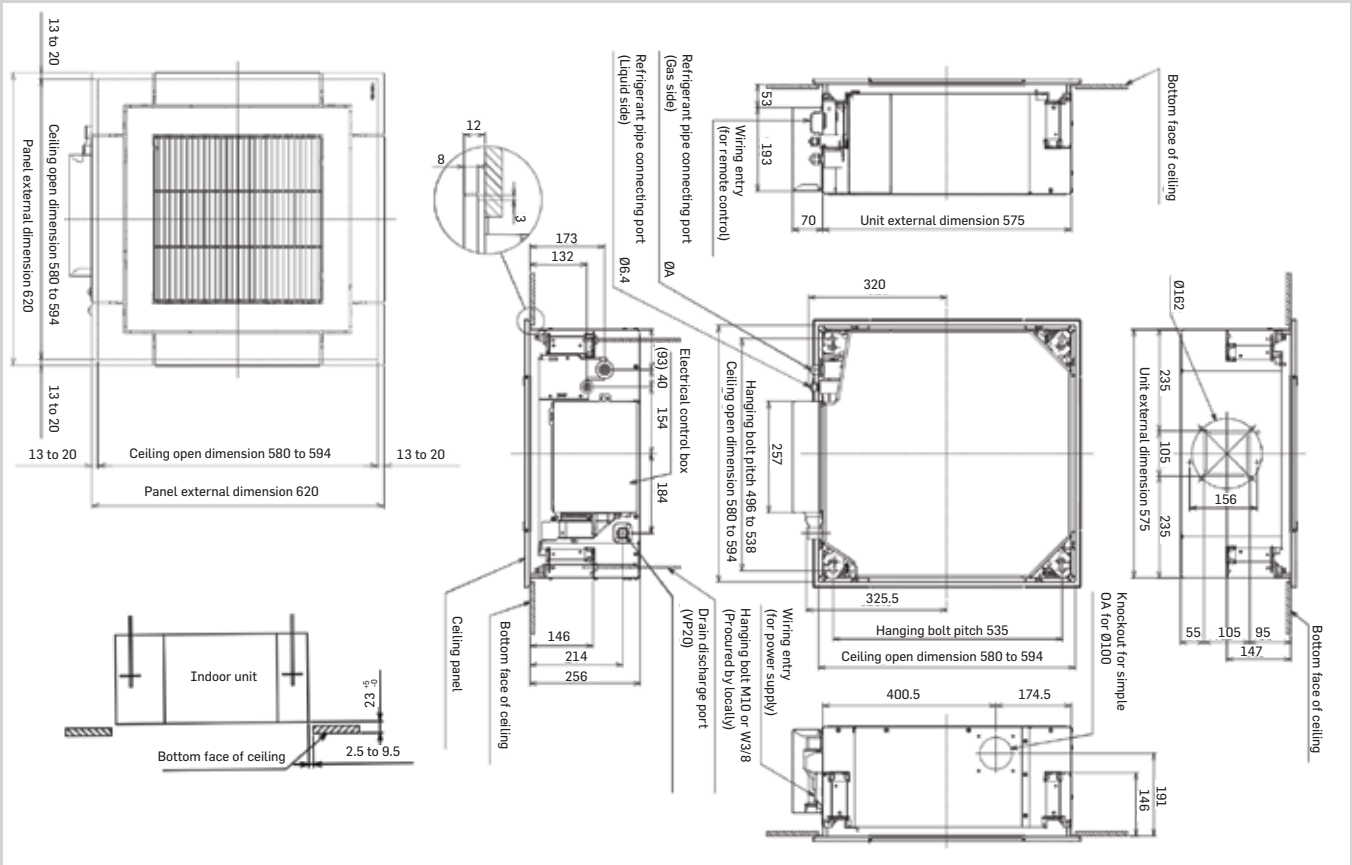

Model	MMD-	A
AP0077MH-E, AP0097MH-E, AP0127MH-E		Ø 9.5
AP0157MH-E, AP0187MH-E		Ø12.7

Options

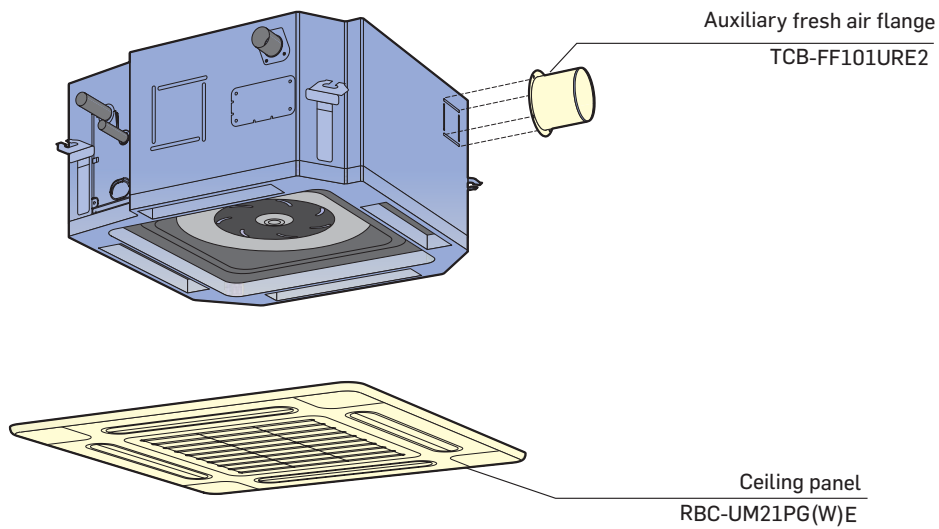

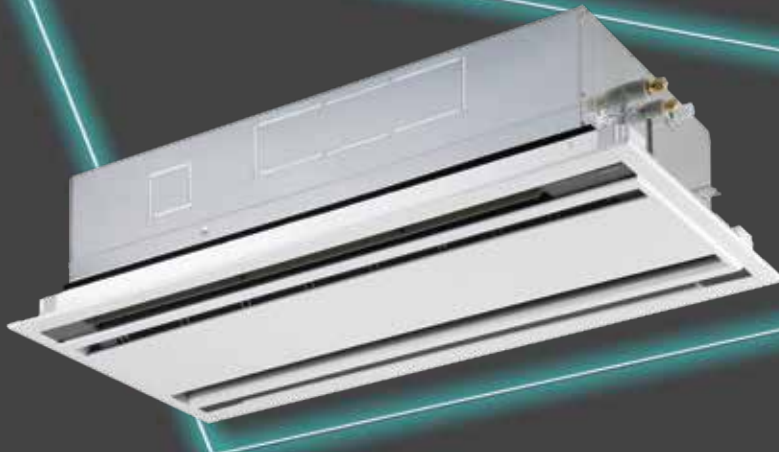

Slim and compact unit

- Unified width of ceiling panel (680mm).
- Condensate drain pump included.
- Available for ceilings up to 3.8m in height. (0.8HP to 3.2HP)
- Easy installation and fine adjustment using the "Adjust-Cover" function.

Remote controller



RBC-AX32UW(W)-E



RBC-ASC11E
RBC-ASC11UE



RBC-AMS55E-EN/ES
RBC-AMSU51-EN/ES

Technical specifications

Model name	MMU-	AP00722WH1	AP0092WH1	AP0122WH1	AP0152WH1	AP0182WH1	AP0242WH1	AP0272WH1	AP0302WH1	AP0362WH1	AP0482WH1	AP0562WH1		
Cooling/Heating capacity*1	(kW)	2.2/2.5	2.8/3.2	3.6/4.0	4.5/5.0	5.6/6.3	7.1/8.0	8.0/9.0	9.0/10.0	11.2/12.5	14.0/16.0	16.0/18.0		
Electrical characteristics	Power requirements	1-phase 50Hz 230V (220-240V) / 1-phase 60Hz 220V (Separate power supply for indoor units required.)												
	Power consumption 50 Hz/60 Hz	(kW)	0.029/0.029		0.030/0.030	0.044/0.044	0.054/0.054		0.064/0.064	0.076/0.076	0.088/0.088	0.117/0.117		
Appearance (Ceiling panel)	Model	RBC-UW283PG(W)-E				RBC-UW803PG(W)-E				RBC-UW1403(W)PG-E				
External dimensions: Main unit (Ceiling panel)*	Height	(mm)	295 (20)				345 (20)							
	Width	(mm)	815 (1050)				1180 (1415)				1600 (1835)			
	Depth	(mm)					570 (680)							
Total weight: Main unit (Ceiling panel)*	(kg)	19 (10)				26 (14)				36 (14)				
Fan unit	Standard air flow (High/Mid/Low)	(m ³ /h)	558/498/450		600/534/450	900/750/618	1050/840/738		1260/900/780	1740/1434/1182	1800/1482/1230	2040/1578/1320		
	Motor output	(w)	20			30		40		50		70		
Connecting pipe	Gas side	(mm)	ø9.5		ø12.7		ø15.9							
	Liquid side	(mm)	ø6.4				ø9.5							
	Drain port (nominal dia.)	(mm)	25 (Polyvinyl chloride tube)											
Sound pressure level*2 (High/Mid/Low)	(dB(A))	34/32/30			35/33/30		38/35/33		40/37/34	42/39/36	43/40/37	46/42/39		
Sound power level (High/Mid/Low)	(dB(A))	49/47/45			50/48/45		53/50/48		55/52/49	57/54/51	58/55/52	61/57/54		

* Figures in parentheses are for ceiling panels.

Note 1: The capacities are measured under the conditions specified by JIS B 8615 based on the reference piping.

Note 2: The sound level are measured in an anechoic chamber in accordance with JIS B 8616.

Normally, the values measured in the actual operating environment become larger than the indicated values due to the effects of external sound.

Note: Rated conditions Cooling: Indoor air temperature 27°C DB/19°C WB, Outdoor air temperature 35°C DB

Heating: Indoor air temperature 20°C DB, Outdoor air temperature 7°C DB/6°C WB

MMU-AP0072WH1 to AP0152WH1

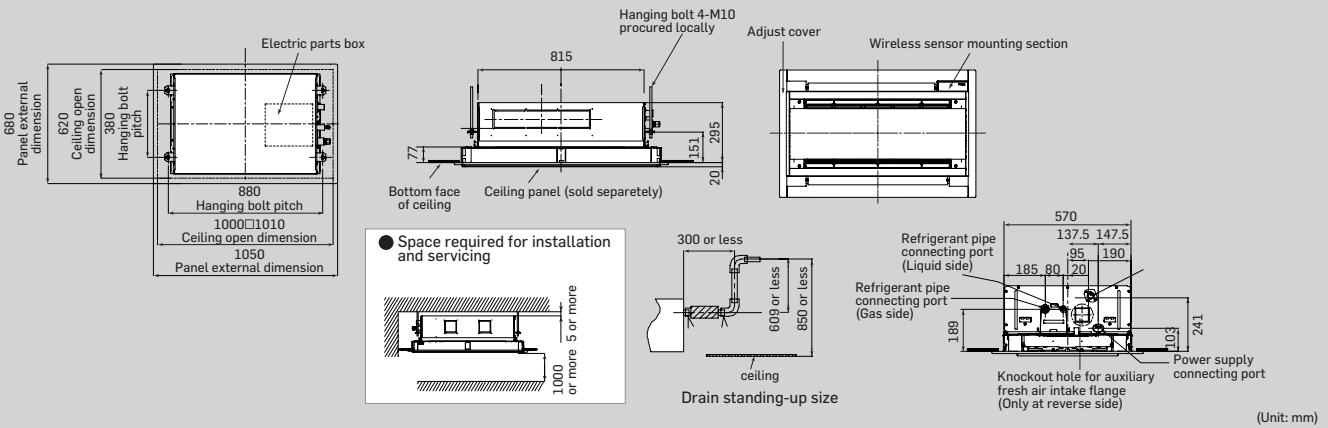

MMU-AP0182WH1 to AP0302WH1

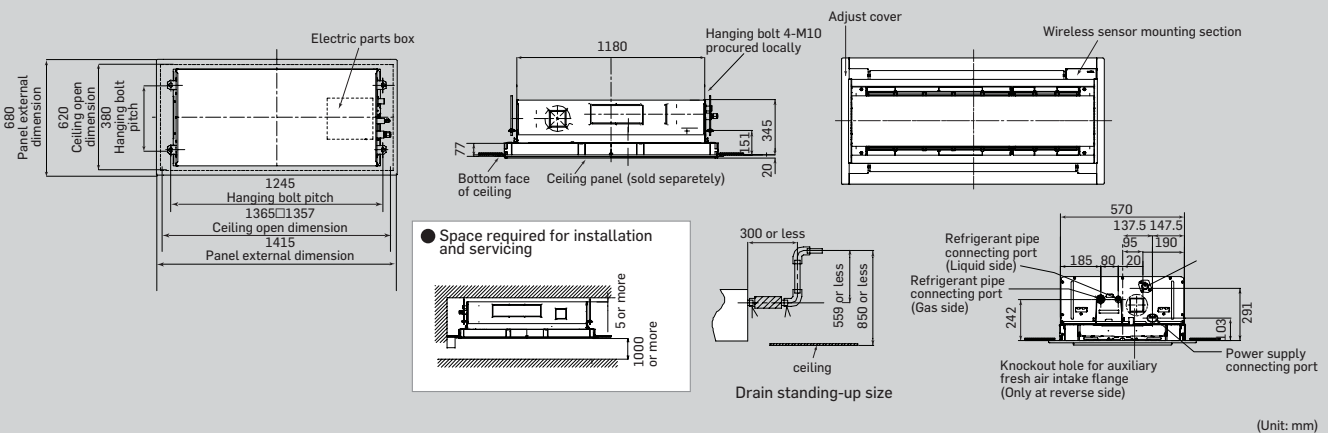

MMU-AP0362WH1 to AP0562WH1

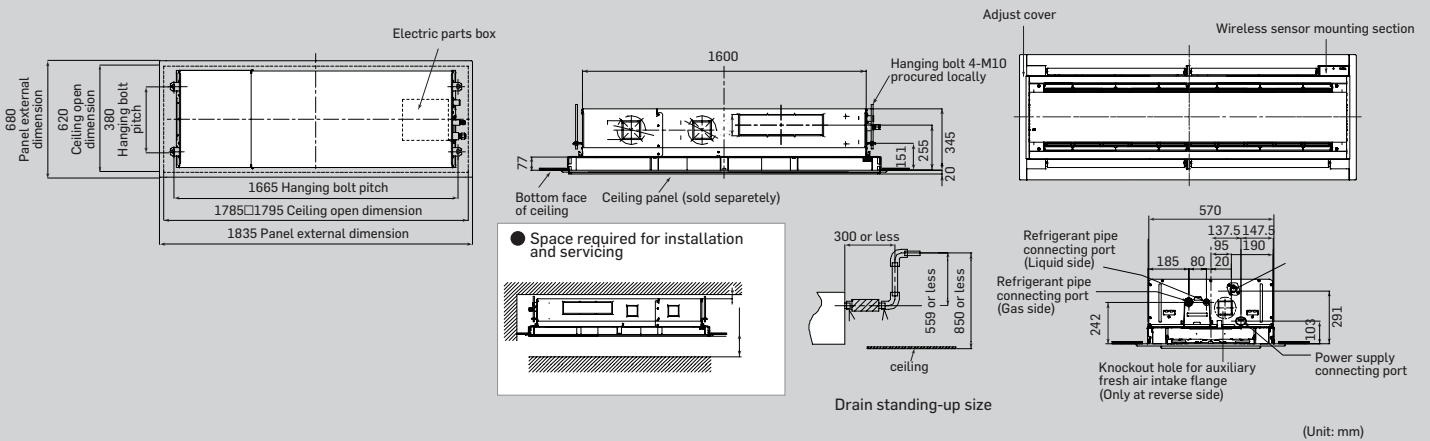

Options

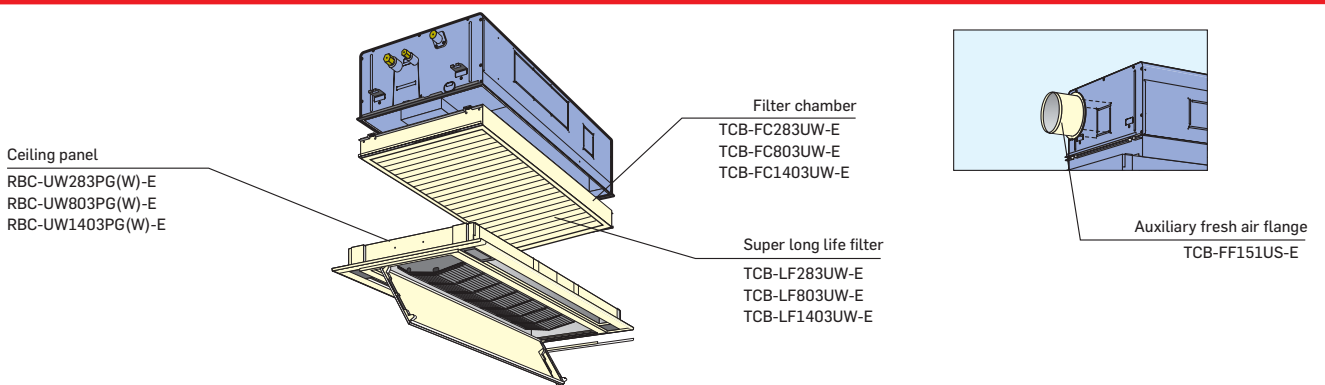

1-way air discharge cassette type

MMU-AP***4YH1-E
MMU-AP***4SH1-E



The perfect choice for hotels and reception areas

Specially designed to ensure silence in office and other applications such as hotel rooms.
Ideal for smaller rooms where one-way air distribution is required.
Able to blow air straight out.
Condensate drain pump included.
Long-life filters fitted as standard.

Fresh air intake is possible (MMU-AP***4SH-E)

Preparations/connection possible with a circle duct flange.

Remote controller

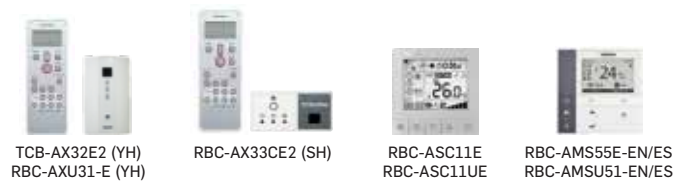

TCB-AX32E2 (YH)
RBC-AXU31-E (YH)

RBC-AX33CE2 (SH)

RBC-ASC11E
RBC-ASC11UE

RBC-AMS55E-EN/ES
RBC-AMSU51-EN/ES

Technical specifications

Model name	MMU-	AP0074YH1-E	AP0094YH1-E	AP0124YH1-E	AP0154SH1-E	AP0184SH1-E	AP0244SH1-E	
Cooling/Heating capacity*1	(kW)	2.2/2.5	2.8/3.2	3.6/4.0	4.5/5.0	5.6/6.3	7.1/8.0	
Electrical characteristics	Power requirements	1-phase 50Hz 230V (220-240V) / 1-phase 60Hz 220V (Separate power supply for indoor units required.)						
	Power consumption 50 Hz/60 Hz (kW)	0.053/0.056		0.042/0.041		0.046/0.045	0.075/0.073	
Appearance (Ceiling panel)	Model	RBC-UY136PG			RBC-US21PGE			
External dimensions: Main unit (Ceiling panel)*	Height (mm)	235 (18)*			200 (20)*			
	Width (mm)	850 (1050)*			1000 (1230)*			
	Depth (mm)	400 (470)*			710 (800)*			
Total weight: Main unit (Ceiling panel)*	(kg)	22 (3.5)*			21 (5.5)*		22 (5.5)*	
Fan unit	Standard air flow (High/Mid/Low) (m ³ /h)	540/480/420			750/690/630	780/720/660		1140/960/810
	Motor output (w)	22			30			
Connecting pipe	Gas side (mm)	ø9.5			ø12.7		ø15.9	
	Liquid side (mm)	ø6.4						
	Drain port (nominal dia.) (mm)	25 (Polyvinyl chloride tube)						
Sound pressure level*2 (High/Mid/Low) (dB(A))		42/39/34			37/35/32	38/36/34		45/41/37
Sound power level (High/Mid/Low) (dB(A))		57/54/49			57/54/51		58/56/52	

* Figures in parentheses are for ceiling panels.

Note 1 : The capacities are measured under the conditions specified by JIS B 8615 based on the reference piping.

Note 2 : The sound level are measured in an anechoic chamber in accordance with JIS B 8616.

Normally, the values measured in the actual operating environment become larger than the indicated values due to the effects of external sound.

Note : Rated conditions Cooling : Indoor air temperature 27°C DB/19°C WB, Outdoor air temperature 35°C DB

Heating : Indoor air temperature 20°C DB, Outdoor air temperature 7°C DB/6°C WB

MMU-AP0074YH1-E to AP0124YH1-E

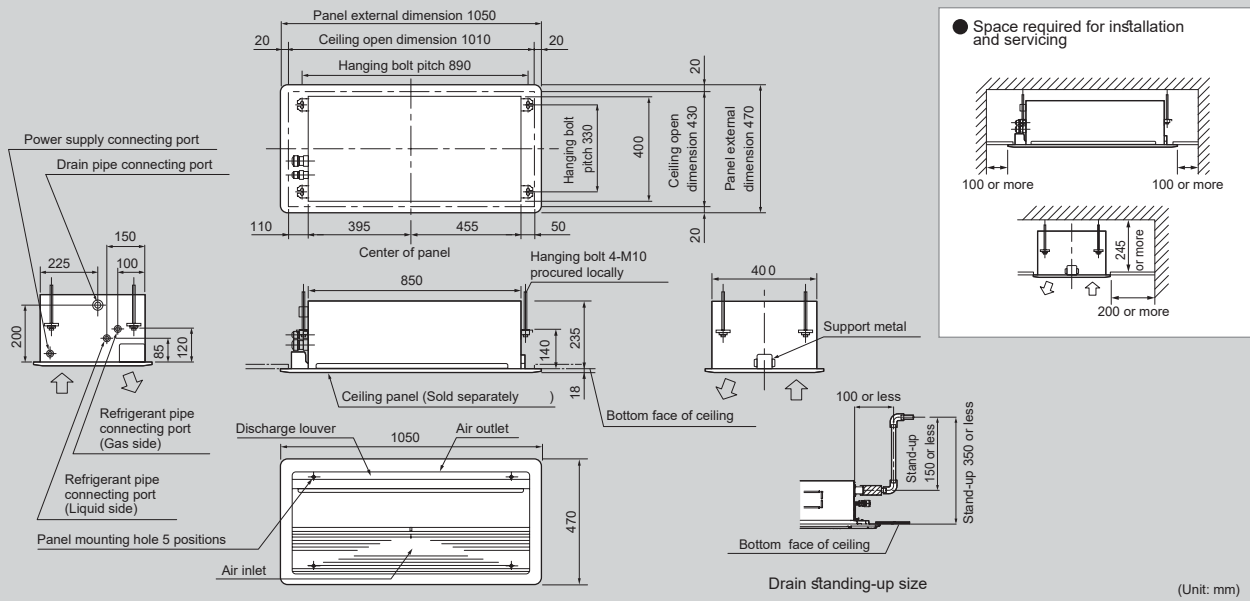

MMU-AP0154SH1-E to AP0244SH1-E

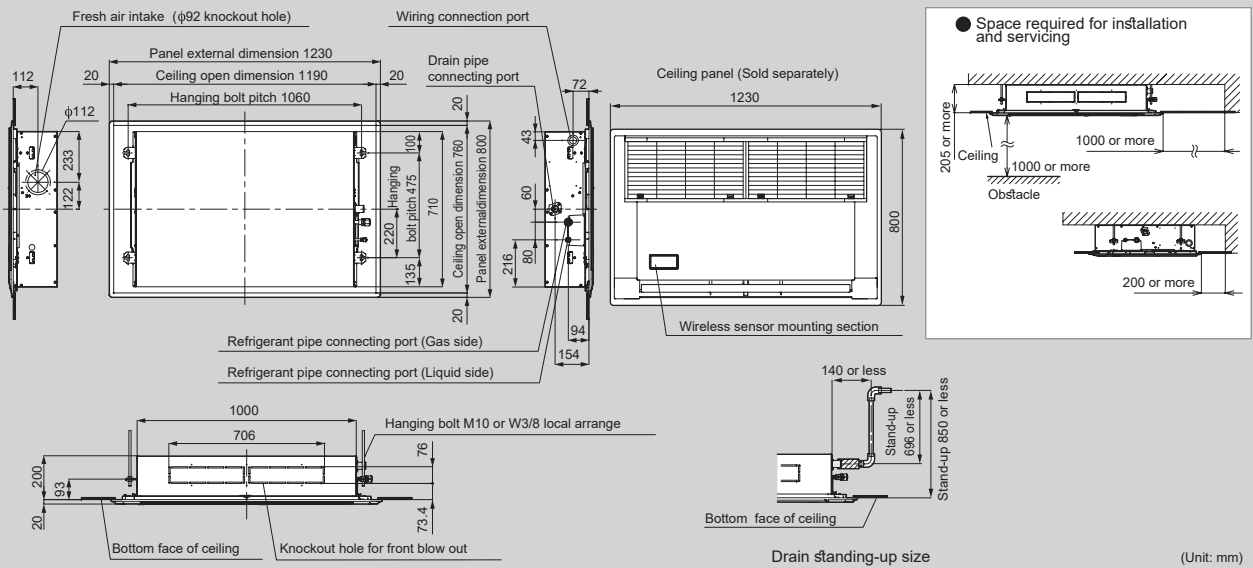

Options

AP0074YH1-E/AP0094YH1-E/AP0124YH1-E

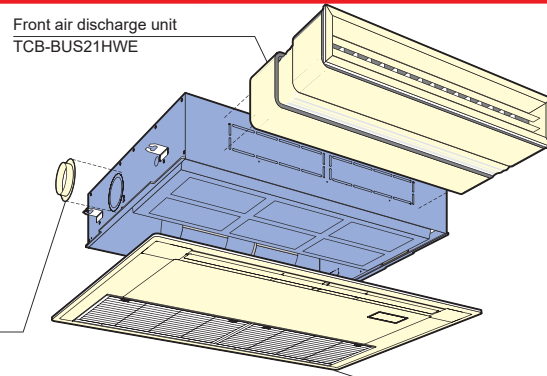
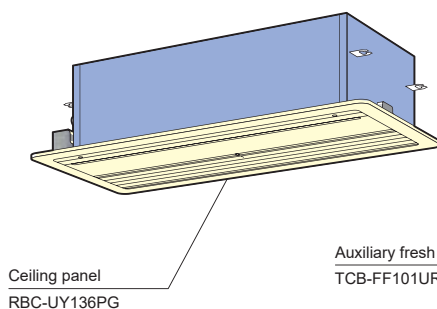

MMU-AP0154SH1-E to AP0244SH1-E



High static pressure

External static pressure can be raised as high as 120 Pa, so that all areas of the room can be reached for an even temperature distribution, no matter how complex the layout.

High-lift drain pump

Built-in high-lift drain pump up to 850 mm.

Remote controller



TCB-AX32E2
RBC-AXU31-E



RBC-ASC11E
RBC-ASC11UE



RBC-AMS55E-EN/ES
RBC-AMSU51-EN/ES

Technical specifications

Model name	MMD-	AP0076BHP1-E	AP0096BHP1-E	AP0126BHP1-E	AP0156BHP1-E	AP0186BHP1-E	AP0246BHP1-E	AP0276BHP1-E	AP0306BHP1-E	AP0366BHP1-E	AP0486BHP1-E	AP0566BHP1-E	
Cooling/Heating capacity*1	(kW)	2.2/2.5	2.8/3.2	3.6/4.0	4.5/5.0	5.6/6.3	7.1/8.0	8.0/9.0	9.0/10.0	11.2/12.5	14.0/16.0	16.0/18.0	
Electrical characteristics	Power requirements	1-phase 50Hz 230V (220-240V) / 1-phase 60Hz 220V (Separate power supply for indoor units required.)											
	Power consumption 50 Hz/60 Hz	(kW)	0.038/0.038	0.043/0.043	0.062/ 0.062		0.077/0.077		0.094/ 0.094	0.172/ 0.172	0.198/0.198		
External dimensions	Height (mm)	275											
	Width (mm)	700			700		1,000			1,400			
	Depth (mm)	750											
Total weight	(kg)	23				30				40			
Fan unit	Standard air flow (High/Mid/Low) (m ³ /h)	540/450/360	570/480/390	798/660/540		1,200/990/870		1,260/1,110/930	1,920/1,620/1,380	2,100/1,740/1,500			
	Motor output (w)	150											
	External static pressure (factory setting) (Pa)	30				40				50			
	External static pressure (Pa)	30-40-50-65-80-100-120 (7 steps)											
Connecting pipe	Gas side (mm)	ø9.5			ø12.7		ø15.9						
	Liquid side (mm)	ø6.4						ø9.5					
	Drain port (nominal dia.) (mm)	25 (Polypropylene tube)											
Sound pressure level*2 (High/Mid/Low) (dB(A))		29/26/23	30/26/23	33/29/25		36/31/27			40/36/33				
Sound power level (High/Mid/Low) (dB(A))		44/41/38	45/41/38	48/44/40		51/46/42			55/51/48				

Note 1 : The capacities are measured under the conditions specified by JIS B 8615 based on the reference piping.

Note 2 : The sound level are measured in an anechoic chamber in accordance with JIS B 8616.

Normally, the values measured in the actual operating environment become larger than the indicated values due to the effects of external sound.

Note : Rated conditions Cooling : Indoor air temperature 27°C DB/19°C WB, Outdoor air temperature 35°C DB

Heating : Indoor air temperature 20°C DB, Outdoor air temperature 7°C DB/6°C WB

MMD-AP0076BHP1-E to AP0566BHP1-E

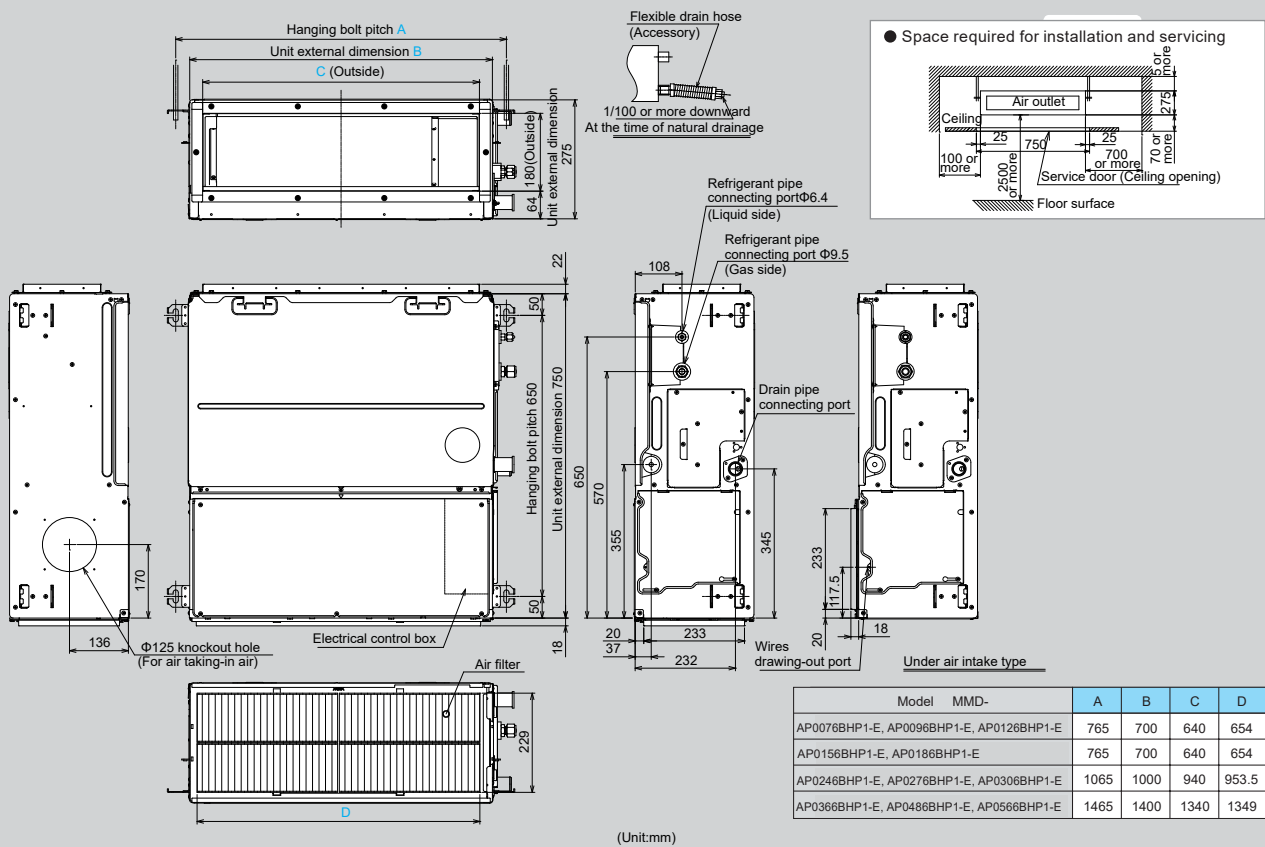

* Standard filter is provided, but deeper filtration filter needs to be purchased locally.

Options

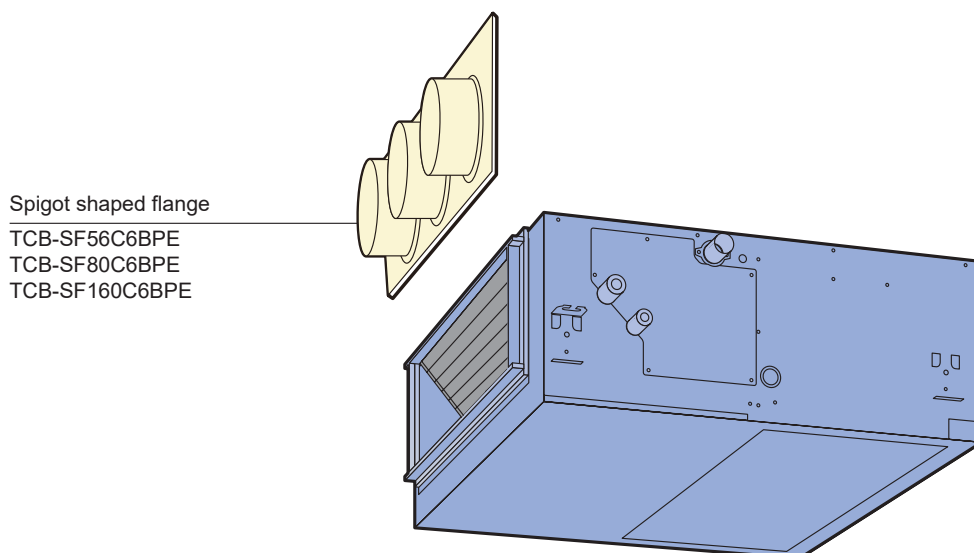



MMD-AP*6HP1-E**
MMD-AP*6HP-E**

Design flexibility

Satisfies all design and application needs.
Compatible with external static pressures up to 200 Pa (2-6HP) and 250 Pa (8 & 10HP).

Can be equipped with the following options:

- Long life filter kit
- Drain pump kit

Construction characteristics

The flexible duct is easily accessible for ease of service and installation.

Unit is provided with an inspection hole that increases ease of access and maintenance.

High-lift drain pump (up to 6 HP)

Built-in high-lift drain pump up to 850 mm.

Remote controller



TCB-AX32E2
RBC-AXU31-E



RBC-ASC11E
RBC-ASC11UE



RBC-AMS55E-EN/ES
RBC-AMSU51-EN/ES

Technical specifications

Model name	MMD-	AP0186HP1-E	AP0246HP1-E	AP0276HP1-E	AP0366HP1-E	AP0486HP1-E	AP0566HP1-E	AP0726HP-E	AP0966HP-E	
Cooling/Heating capacity*1	(kW)	5.6/6.3	7.1/8.0	8.0/9.0	11.2/12.5	14.0/16.0	16.0/18.0	22.4/25.0	28.0/31.5	
Electrical characteristics	Power requirements	1-phase 50Hz 230V (220-240V) / 1-phase 60Hz 220V (Separate power supply for indoor units required.)								
	Power consumption 50 Hz/60 Hz (kW)	0.085	0.115		0.198	0.230	0.290	0.54	0.79	
External dimensions	Height (mm)	298						448		
	Width (mm)	1,000			1,400			1,400		
	Depth (mm)	750			750			900		
Total weight (kg)		34			43			97		
Fan unit	Standard air flow (High/Mid/Low) (m ³ /h)	800 (660/550)	1,200 (970/800)		1,920 (1,560/1,340)	2,100 (1,740/1,420)	2,400 (2,040/1,660)	3,800 (3,200/2,500)	4,800 (4,200/3,500)	
	Motor output (w)	250			350			250		
	External static pressure (factory setting) (Pa)	100						150		
	External static pressure (Pa)	50-75-125-150-175-200 (7steps)						50-83-117-150-183-217-250 (7 steps)		
Connecting pipe	Gas side (mm)	ø12.7	ø15.9			ø22.2				
	Liquid side (mm)	ø6.4	ø9.5			ø12.7				
	Drain port (nominal dia.) (mm)	25 (Polyvinyl chloride tube)						25 (Polyvinyl Chloride Tube)		
Sound pressure level*2 (High/Mid/Low) (dB(A))		37 (32/30)	38 (34/31)		41 (37/34)	42 (40/35)	45 (42/37)	44 (40/36)	46 (42/38)	
Sound power level (High/Mid/Low) (dB(A))		60 (54/50)	60 (55/51)		62 (57/53)	65 (62/54)	68 (64/56)	79 (75/71)	81 (77/73)	

Note 1 : The cooling capacities and electrical characteristics are measured under the conditions specified by JIS B 8615 based on the reference piping.

Note 2 : The sound level are measured in an anechoic chamber in accordance with JIS B 8616.

Normally, the values measured in the actual operating environment become larger than the indicated values due to the effects of external sound.

Note : Rated conditions Cooling : Indoor air temperature 27°C DB/19°C WB, Outdoor air temperature 35°C DB

Heating : Indoor air temperature 20°C DB, Outdoor air temperature 7°C DB/6°C WB

MMD-AP0186HP1-E to AP0276HP1-E

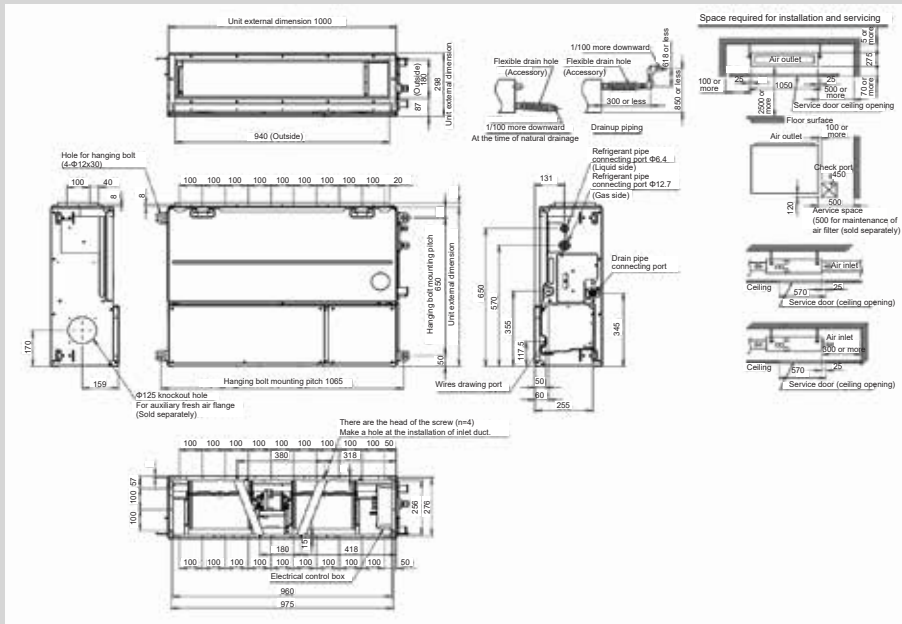

MMD-AP0726HP-E, AP0966HP-E

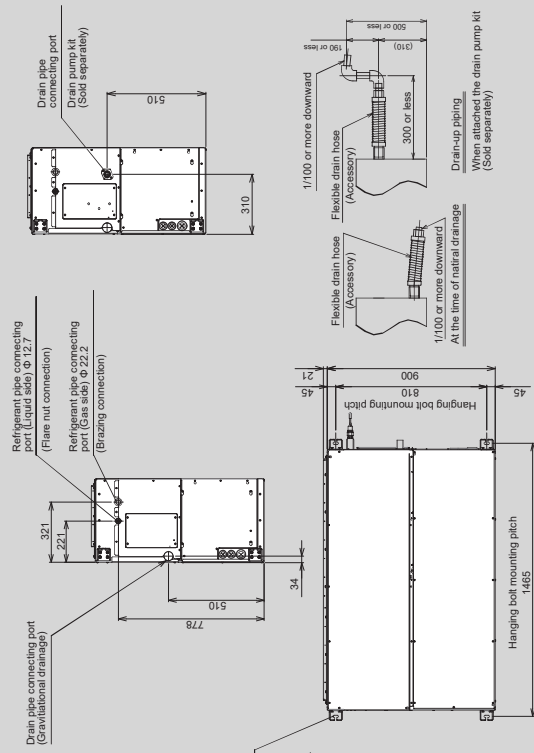

MMD-AP0366HP1-E to AP0566HP1-E

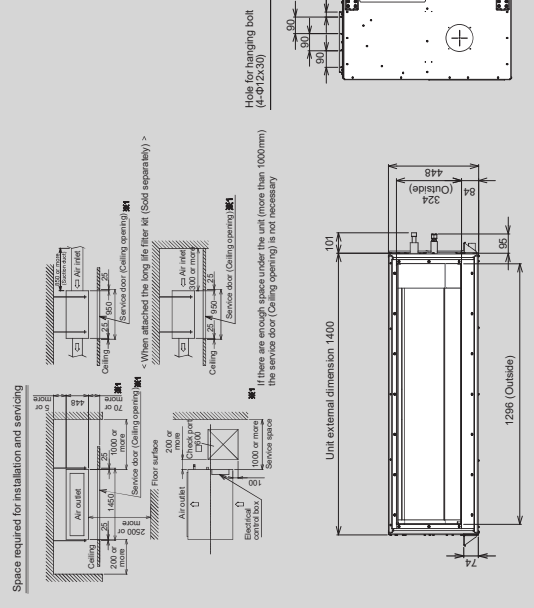
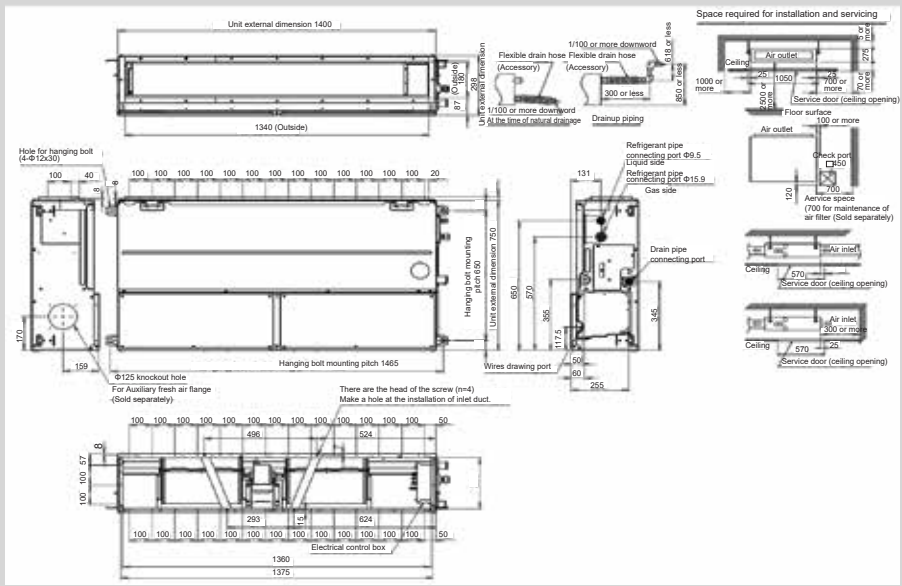

Options

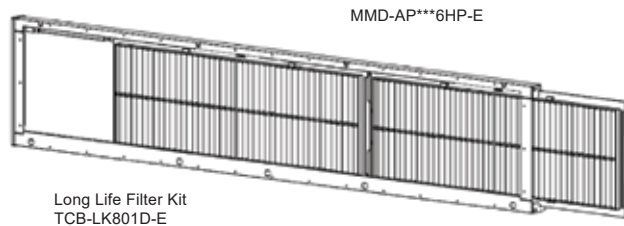

Long Life Filter Kit
TCB-LK801D-E
TCB-LK1401D-E
TCB-LK2801DP-E

MMD-AP***6HP-E

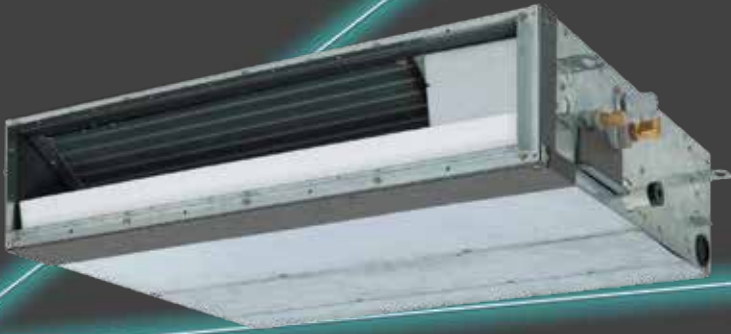

Functional design

Only 210 mm in height for greater application flexibility.
4-step static pressure setup.
Concealed installation within a ceiling void.
Auxiliary fresh air intake available.

High-lift drain pump

Built-in high-lift drain pump up to 850 mm.

Slim & quiet

Perfect comfort throughout the room.
Can be used with any style of air diffuser.
Quiet, powerful operation.

Remote controller



TCB-AX32E2
RBC-AXU31-E

RBC-ASC11E
RBC-ASC11UE

RBC-AMS55E-EN/ES
RBC-AMSU51-EN/ES

Technical specifications

Model name	MMD-	AP0074SPH1-E	AP0094SPH1-E	AP0124SPH1-E	AP0154SPH1-E	AP0184SPH1-E	AP0244SPH1-E	AP0274SPH1-E	
Cooling/Heating capacity*1	(kW)	2.2/2.5	2.8/3.2	3.6/4.0	4.5/5.0	5.6/6.3	7.1/8.0	8.0/9.0	
Electrical characteristics	Power requirements	1-phase 50Hz 230V (220-240V) / 1-phase 60Hz 220V (Separate power supply for indoor units required.)							
	Power consumption 50 Hz/60 Hz (kW)	0.039/0.037		0.043/0.041	0.045/0.043	0.054/0.052	0.105/0.105		
External dimensions	Height (mm)	210							
	Width (mm)	845					1140		
	Depth (mm)	645							
Total weight	(kg)	22			23		29		
Fan unit	Standard air flow (High/Mid/Low) (m³/h)	540/470/400		600/520/450	690/600/520	780/680/580	1,080/1,000/900		
	Motor output (w)	60							
	External static pressure (Pa)	6-16-31-46 (4 steps)			5-15-30-45 (4 steps)		4-14-29-44(4 steps)	2-12-22-42 (4 steps)	
Connecting pipe	Gas side (mm)	ø9.5			ø12.7		ø15.9		
	Liquid side (mm)	ø6.4							
	Drain port (nominal dia.) (mm)	25 (Polyvinyl chloride tube)							
Sound pressure level*2 (High/Med./Low)	Under air inlet (dB(A))	36/33/30	38/35/32	39/36/33	40/38/36	49/47/44			
	Back air inlet (dB(A))	28/26/24	29/27/25	32/30/28	33/31/29	38/36/33			
Sound power level (High/Med./Low)	Under air inlet (dB(A))	51/48/45	53/50/47	54/51/48	55/53/51	64/62/59			
	Back air inlet (dB(A))	43/41/39	44/42/40	47/45/43	48/46/44	53/51/48			

Note 1 : The capacities are measured under the conditions specified by JIS B 8615 based on the reference piping.

Note 2 : The sound level are measured in an anechoic chamber in accordance with JIS B 8616.

Normally, the values measured in the actual operating environment become larger than the indicated values due to the effects of external sound.

Note : Rated conditions Cooling : Indoor air temperature 27°C DB/19°C WB, Outdoor air temperature 35°C DB
Heating : Indoor air temperature 20°C DB, Outdoor air temperature 7°C DB/6°C WB

MMD-AP0074SPH1-E to AP0274SPH1-E

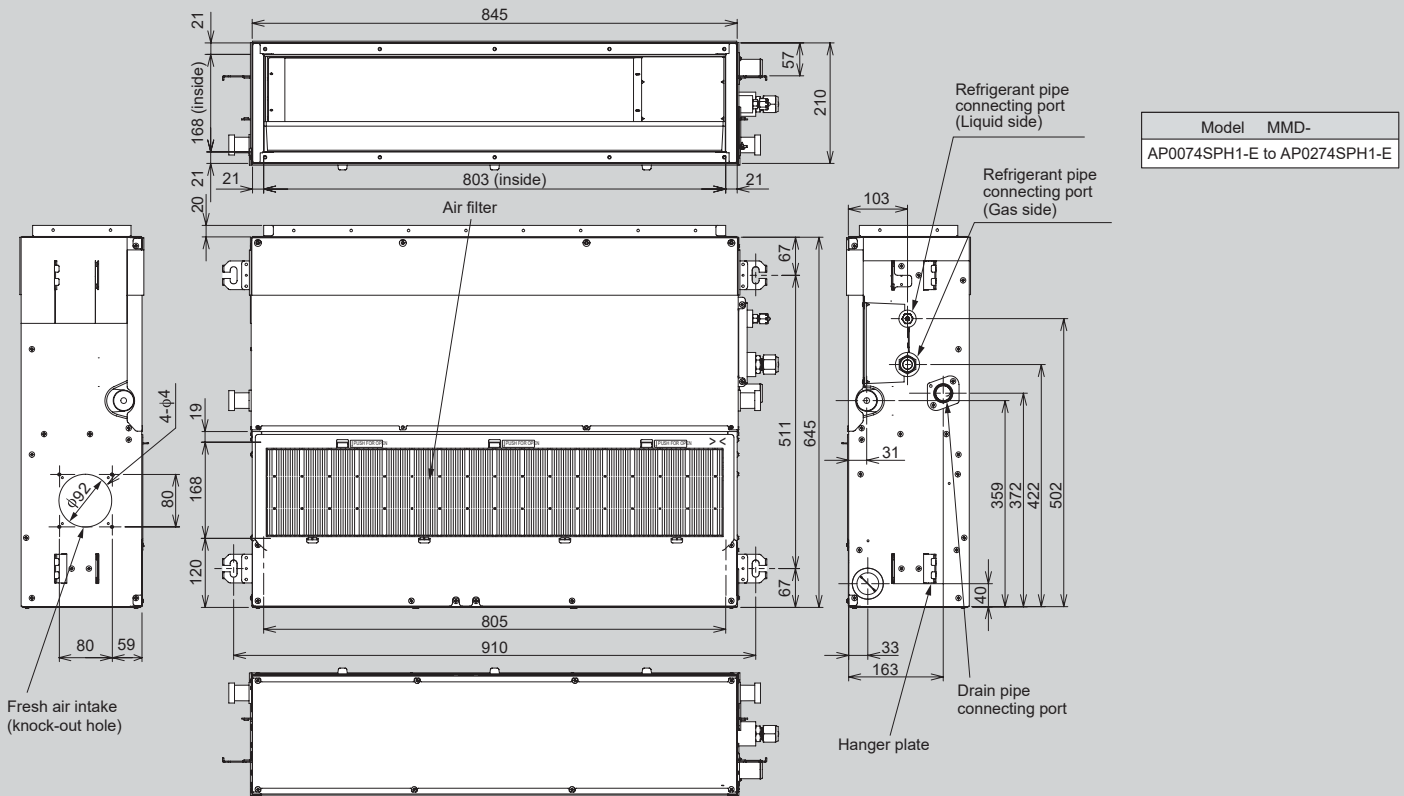

● Space required for installation and servicing

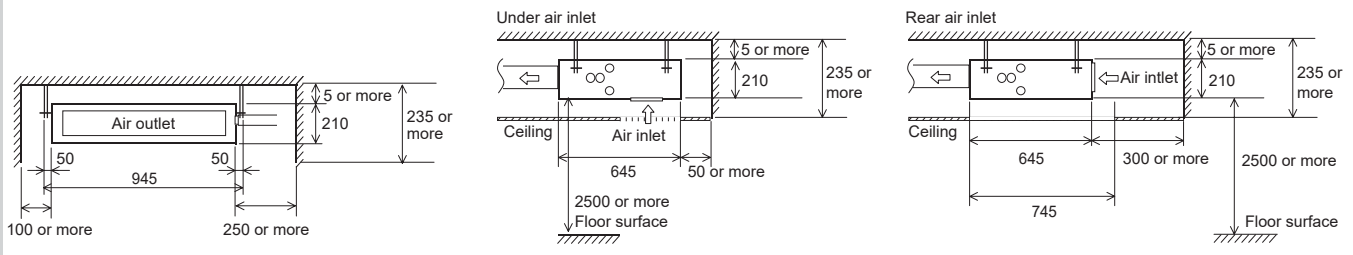

(Unit: mm)

Options

Auxiliary fresh air flange
TCB-FF101URE2

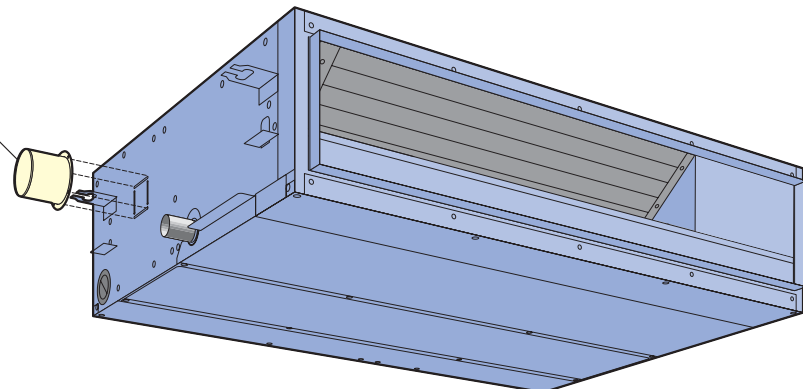



Smooth curve for pliant Shape

All-new chassis and rounded design, These new models from Toshiba have been developed in response to customer needs for ceiling units that match their room interiors aesthetically.

Smooth curve for pliant Shape

New fan is provided with the turbulence prevention rib to optimize the ventilation.

The new design from Toshiba increases air volume while decreasing noise levels. Airflow of Toshiba's new ceiling type units (4HP to 6HP) can reach 4.3 meters.

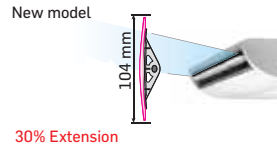
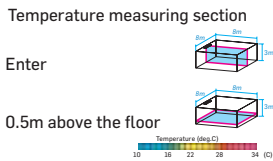

New Designed Wide Flap

The new air outlet design ensures large air volume flow and a large noise reduction.

Flap control

The airflow angle is automatically set to the most suitable setting according to your cooling or heating needs, and an automatic swing mode enables airflow to reach all areas of the room to create a comfortable ambience.

Remote controller



RBC-AX33CE

RBC-ASC11E
RBC-ASC11UE

RBC-AMS55E-EN/ES
RBC-AMSU51-EN/ES

Technical specifications

Model name	MMC-	AP0158HP-E	AP0188HP-E	AP0248HP-E	AP0278HP-E	AP0368HP-E	AP0488HP-E	AP0568HP-E	
Cooling/Heating capacity*1	(kW)	4.5/5.0	5.6/6.3	7.1/8.0	8.0/9.0	11.2/12.5	14.0/16.0	16.0/18.0	
Electrical characteristics	Power requirements	1-phase 50Hz 230V (220-240V) / 1-phase 60Hz 220V (Separate power supply for indoor units required.)							
	Power consumption 50 Hz/60 Hz	(kW)	0.033/0.033	0.034/0.034	0.067/0.067		0.083/0.083		0.111/0.111
External dimensions	Height (mm)	235							
	Width (mm)	950		1,269		1,586			
	Depth (mm)	690							
Total weight	(kg)	24		30		39			
Fan unit	Standard air flow (High/Mid/Low)	(m ³ /h)	840 /690/540	960 /720/540	1,440 /1,020/750		1,860 /1,350/1,020	1,860 /1,530/1,200	2,040 /1,650/1,260
	Motor	(w)	94		94		139		
Connecting pipe	Gas side	(mm)	ø12.7		ø15.9				
	Liquid side	(mm)	ø6.4		ø9.5				
	Drain port (nominal dia.)	(mm)	20 (Polyvinyl chloride tube)						
Sound pressure level*2 (High/Mid/Low)	(dB(A))	36/34/28	37/35/28	41/36/29		44/38/32	44/41/35	46/42/36	
Sound power level (High/Mid/Low)	(dB(A))	51/49/43	52/50/43	56/51/44		59/53/47	59/56/50	61/57/51	

Note 1 : The capacities are measured under the conditions specified by JIS B 8615 based on the reference piping.

Note 2 : The sound level are measured in an anechoic chamber in accordance with JIS B 8616.

Normally, the values measured in the actual operating environment become larger than the indicated values due to the effects of external sound.

Note : Rated conditions Cooling : Indoor air temperature 27°C DB/19°C WB, Outdoor air temperature 35°C DB

Heating : Indoor air temperature 20°C DB, Outdoor air temperature 7°C DB/6°C WB

MMC-AP0158HP-E to AP0568HP-E

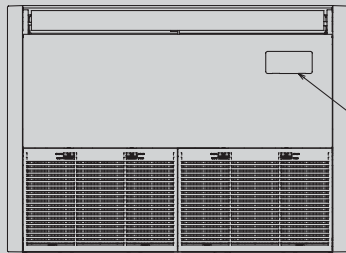
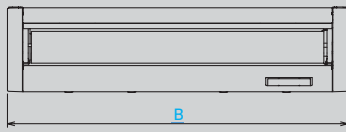
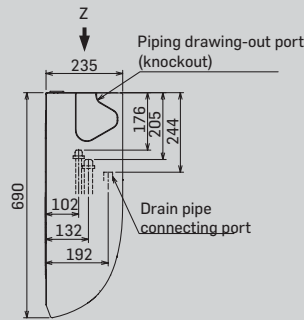
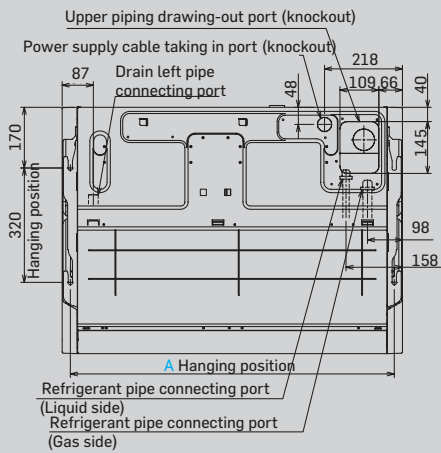

Wireless sensor mounting section

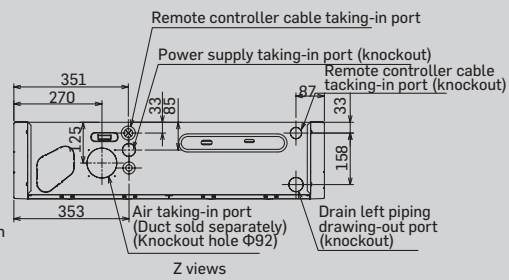

Model	MMC-	A	B
AP0158HP-E, AP0188HP-E		906	950
AP0248HP-E, AP0278HP-E		1223	1269
AP0368HP-E, AP0488HP-E, AP0568HP-E		1540	1586

● Space required for installation and servicing

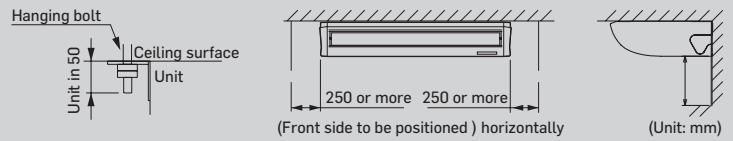

Options

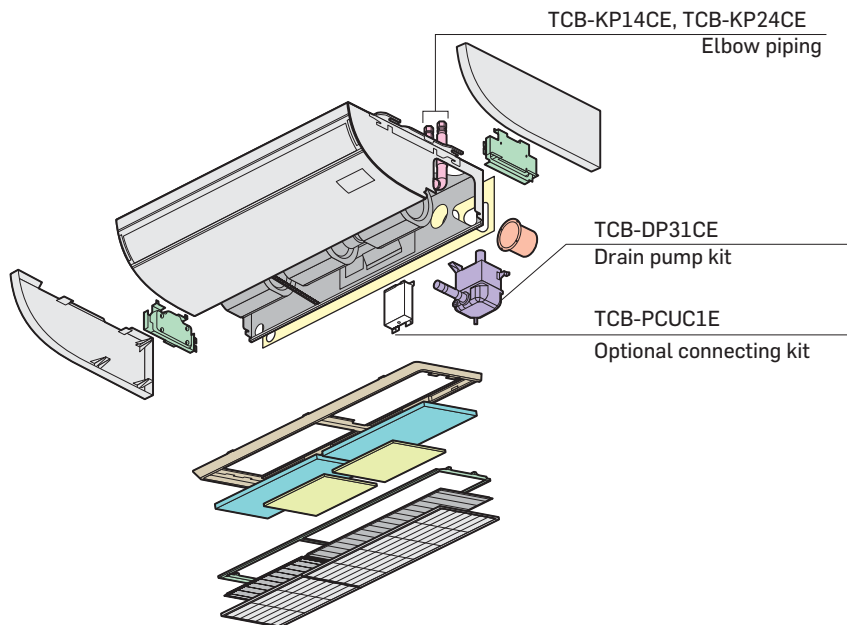



Elegant and slim

This modern and aesthetic looking high-wall is of elegant and slim design and easily blends with several types of room interiors.

Toshiba's 7-Series Hi Wall units guarantee total comfort with low noise operation and ensure uniform air distribution with the help of a directional auto switch louver. The unit is designed for long life operation with specially coated fins.



Remote controller

MMK- AP0077HP to AP0247HP

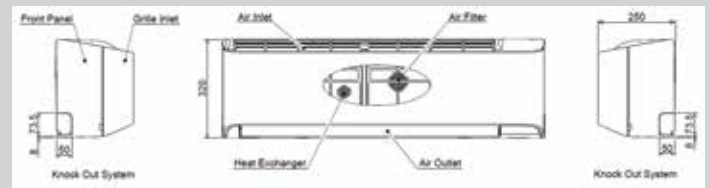
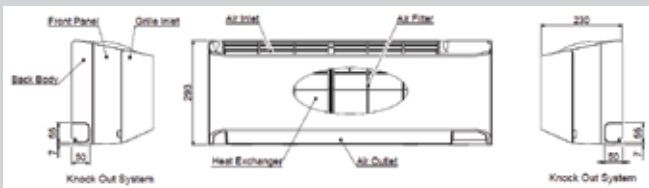
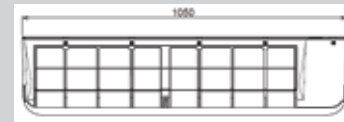
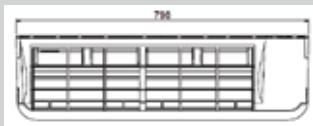

AP0077HP-E, AP0097HP-E and AP0127HP-E

AP0157HP-E, AP0187HP-E and AP0247HP-E

Technical specifications

Model name	MMK-	AP0077HP-E	AP0097HP-E	AP0127HP-E	AP0157HP-E	AP0187HP-E	AP0247HP-E	
Cooling/Heating capacity*1	(kW)	2.2/2.5	2.8/3.2	3.6/4.0	4.5/5.0	5.6/6.3	7.1/8.0	
Electrical characteristics	Power requirements	1-phase 50Hz 230V (220-240V) (Separate power supply for indoor units required.)						
	Power consumption 50 Hz/60 Hz	(kW)	0.015	0.016	0.017	0.028	0.032	0.050
External dimensions	Height	(mm)	293			320		
	Width	(mm)	798			1050		
	Depth	(mm)	230			250		
Total weight	(kg)	11			16			
Fan unit	Standard air flow (High/Low)	(m ³ /h)	480/300	510/300	540/300	840/550	900/550	1200/600
	Motor output	(w)	30			-		
Connecting pipe	Gas side	(mm)	ø9.5			ø12.7	ø15.88	
	Liquid side	(mm)	ø6.4			ø6.35	ø9.53	
	Drain port (nominal dia.)	(mm)	16 (polyvinyl chloride tube)			-		
Sound pressure level*2 (High/Low)	(dB(A))	35/25	36/25	37/25	40/32	41/32	45/33	

Note 1: The capacities are measured under the conditions specified by JIS B 8615 based on the reference piping.

Note 2: The sound level are measured in an anechoic chamber in accordance with JIS B 8616.

Normally, the values measured in the actual operating environment become larger than the indicated values due to the effects of external sound.

Note: Rated conditions Cooling: Indoor air temperature 27°C DB/19°C WB, Outdoor air temperature 35°C DB

Heating: Indoor air temperature 20°C DB, Outdoor air temperature 7°C DB/6°C WB

Console type

MML-AP*4NH1-E**



Wide outlet

Elegant & simple design makes this unit a perfect fit for shops, office buildings, and luxury apartments. Bottom flow functionality ensures comfortable air bi-flow for an advantages in heating and floor warming. Toshiba's Console type units offer unrivaled convenience through multi-function and ease of making adjustments by the occupants using the wireless remote controller.



Remote controller

MML-AP0074NH1-E to AP0184NH1-E

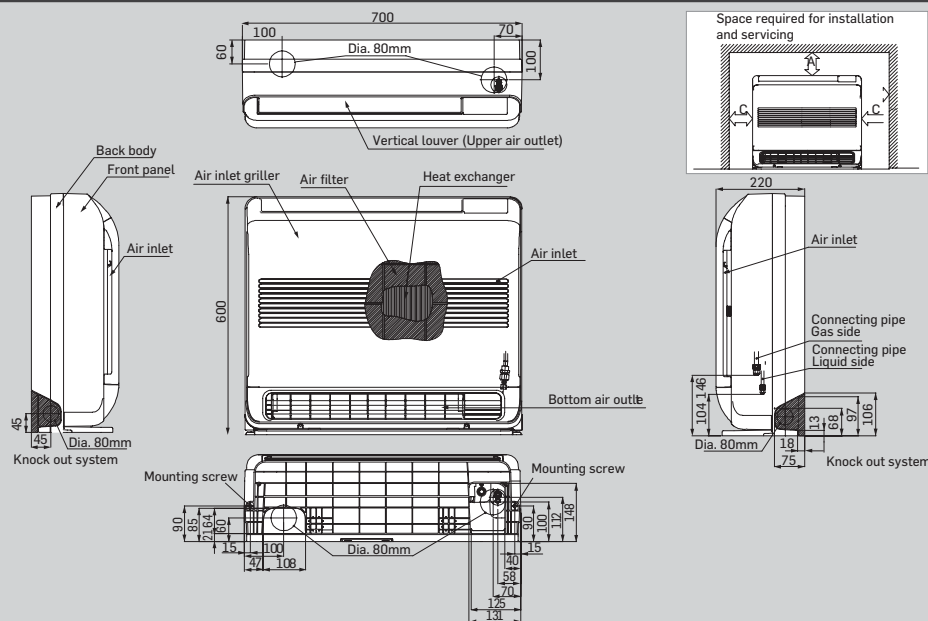

(Unit: mm)

Technical specifications

Model name	MML-	AP0074NH1-E	AP0094NH1-E	AP0124NH1-E	AP0154NH1-E	AP0184NH1-E
Cooling/Heating capacity*1	(kW)	2.2/2.5	2.8/3.2	3.6/4.0	4.5/5.0	5.6/6.3
Electrical characteristics	Power requirements	1-phase 50Hz 230V (220-240V) / 1-phase 60Hz 220V (Separate power supply for indoor units required.)				
	Power consumption 50 Hz/60 Hz	(kW)	0.021		0.025	0.034
External dimensions	Height	(mm)		600		
	Width	(mm)		700		
	Depth	(mm)		220		
Total weight	(kg)			17		
Fan unit	Standard air flow (High/Mid/Low)	(m ³ /h)	510/366/282	552/408/324	624/468/384	726/528/426
	Motor output	(w)		41		
Connecting pipe	Gas side	(mm)	ø9.5		ø12.7	
	Liquid side	(mm)	ø6.4			
	Drain port (nominal dia.)	(mm)	16 (Polyvinyl chloride tube)			
Sound pressure level*2 (High/Mid/Low)	(dB(A))	38/32/26		40/34/29	43/37/31	47/40/34
Sound power level (High/Mid/Low)	(dB(A))	53/41		55/44	58/46	62/55

Note 1 : The capacities are measured under the conditions specified by JIS B 8615 based on the reference piping.

Note 2 : The sound level are measured in an anechoic chamber in accordance with JIS B 8616.

Normally, the values measured in the actual operating environment become larger than the indicated values due to the effects of external sound.

Note : Rated conditions Cooling : Indoor air temperature 27°C DB/19°C WB, Outdoor air temperature 35°C DB

Heating : Indoor air temperature 20°C DB, Outdoor air temperature 7°C DB/6°C WB



Slim & compact design

Under-window mounting does not block lighting.
Indoor unit size of 2.2 kW to 7.1 kW is the same.

Slim & compact design

Air distribution can be reversed to suit occupant preference.

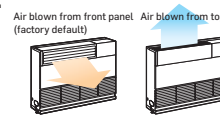

Remote controller

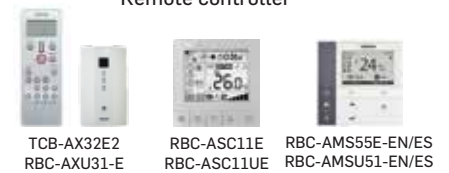

MML-AP0074H1-E to AP0244H1-E

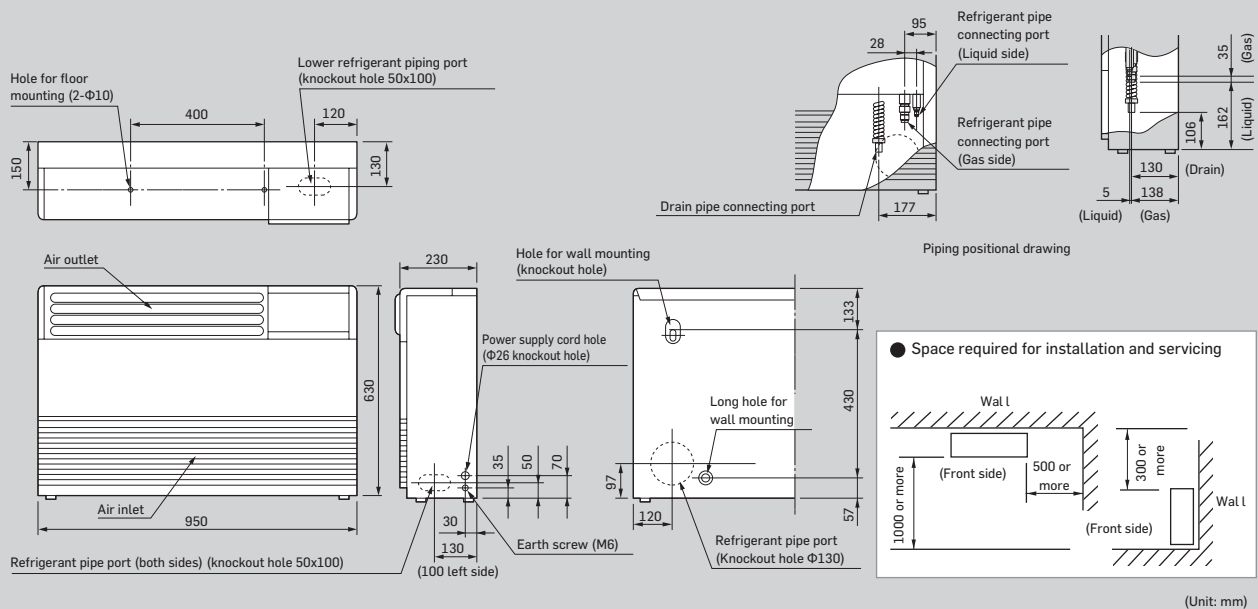

(Unit: mm)

Technical specifications

Model name	MML-	AP0074H1-E	AP0094H1-E	AP0124H1-E	AP0154H1-E	AP0184H1-E	AP0244H1-E
Cooling/Heating capacity*1	(kW)	2.2/2.5	2.8/3.2	3.6/4.0	4.5/5.0	5.6/6.3	7.1/8.0
Electrical characteristics	Power requirements	1-phase 50Hz 230V (220-240V) / 1-phase 60Hz 220V (Separate power supply for indoor units required.)					
	Power consumption 50 Hz/60 Hz	0.056/0.053		0.092/0.092		0.102/0.113	
External dimensions	Height	630					
	Width	950					
	Depth	230					
Total weight	(kg)	37				40	
Fan unit	Standard air flow (High/Mid/Low)	480/420/360		900/780/650		1080/930/780	
	Motor output	45				70	
Connecting pipe	Gas side	ø9.5			ø12.7		ø15.9
	Liquid side	ø6.4					
	Drain port (nominal dia.)	20 (Polyvinyl chloride tube)					
Sound pressure level*2 (High/Mid/Low)	(dB(A))	39/37/35		45/41/38		49/44/39	
Sound power level (High/Mid/Low)	(dB(A))	54/52/50		60/56/53		64/59/54	

Note 1: The capacities are measured under the conditions specified by JIS B 8615 based on the reference piping.

Note 2: The sound level are measured in an anechoic chamber in accordance with JIS B 8616.

Normally, the values measured in the actual operating environment become larger than the indicated values due to the effects of external sound.

Note: Rated conditions Cooling: Indoor air temperature 27°C DB/19°C WB, Outdoor air temperature 35°C DB
Heating: Indoor air temperature 20°C DB, Outdoor air temperature 7°C DB/6°C WB

Floor standing concealed type

MML-AP*4BH1-E**



Cool air makes for a pleasant indoor environment

Installation under a window makes it easy to air condition any room effectively.

Easy maintenance

Simplified design of fan and drainage pipe eases maintenance.

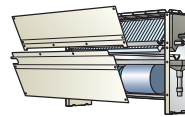

Remote controller



TCB-AX32E2
RBC-AXU31-E

RBC-ASC11E
RBC-ASC11UE

RBC-AMS55E-EN/ES
RBC-AMSU51-EN/ES

MML-AP0074BH1-E to AP0244BH1-E

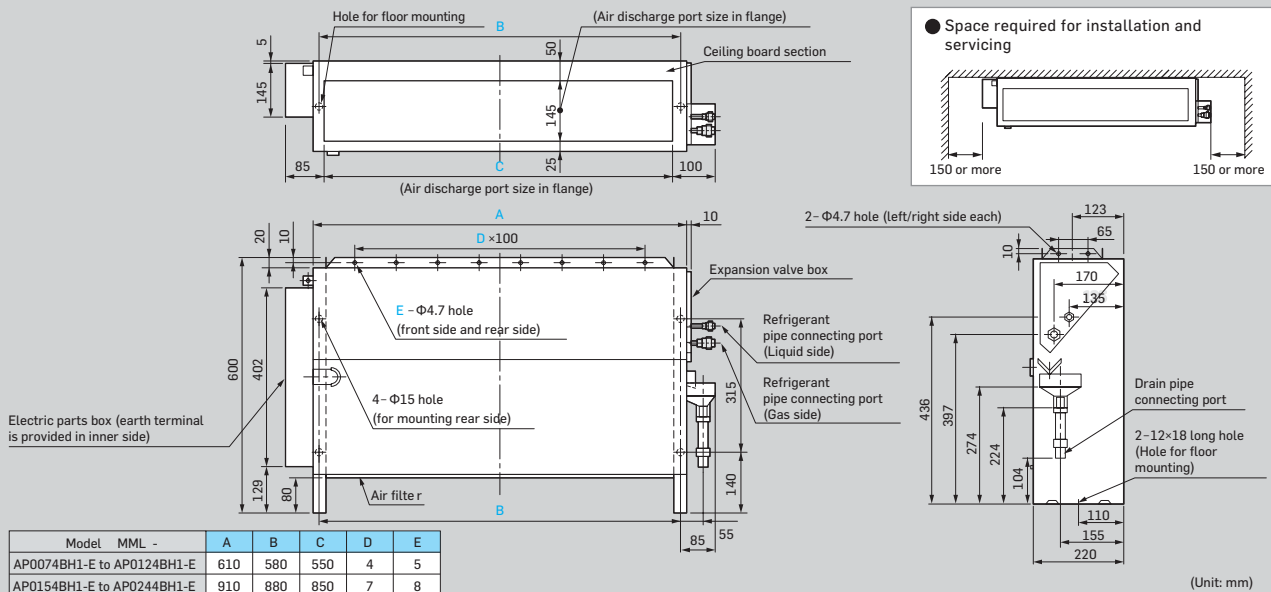

Technical specifications

Model name	MML-	AP0074BH1-E	AP0094BH1-E	AP0124BH1-E	AP0154BH1-E	AP0184BH1-E	AP0244BH1-E	
Cooling/Heating capacity*1	(kW)	2.2/2.5	2.8/3.2	3.6/4.0	4.5/5.0	5.6/6.3	7.1/8.0	
Electrical characteristics	Power requirements	1-phase 50Hz 230V (220-240V) / 1-phase 60Hz 220V (Separate power supply for indoor units required.)						
	Power consumption 50 Hz/60 Hz (kW)	0.056/0.058		0.090/0.096		0.095/0.110		
External dimensions	Height (mm)	600						
	Width (mm)	745				1,045		
	Depth (mm)	220						
Total weight	(kg)	21				29		
Fan unit	Standard air flow (High/Mid/Low) (m ³ /h)	460/400/300			740/600/490		950/790/640	
	Motor output (w)	19			70			
Connecting pipe	Gas side (mm)	ø9.5			ø12.7		ø15.9	
	Liquid side (mm)	ø6.4						
	Drain port (nominal dia.) (mm)	20 (Polyvinyl chloride tube)						
Sound pressure level*2 (High/Mid/Low) (dB(A))		36/34/32				42/37/33		
Sound power level (High/Mid/Low) (dB(A))		54/52/50						

Note 1 : The capacities are measured under the conditions specified by JIS B 8615 based on the reference piping.

Note 2 : The sound level are measured in an anechoic chamber in accordance with JIS B 8616.

Normally, the values measured in the actual operating environment become larger than the indicated values due to the effects of external sound.

Note : Rated conditions Cooling : Indoor air temperature 27°C DB/19°C WB, Outdoor air temperature 35°C DB

Heating : Indoor air temperature 20°C DB, Outdoor air temperature 7°C DB/6°C WB

Floor standing concealed type

MML-AP***4BH1-E



Cool air makes for a pleasant indoor environment

Installation under a window makes it easy to air condition any room effectively.

Easy maintenance

Simplified design of fan and drainage pipe eases maintenance.

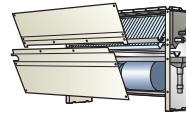

REMOTE CONTROLS



TCB-AX32E2
RBC-AXU31-E



RBC-AMS41E

RBC-AMS54E

MML-AP0074BH1-E to AP0244BH1-E

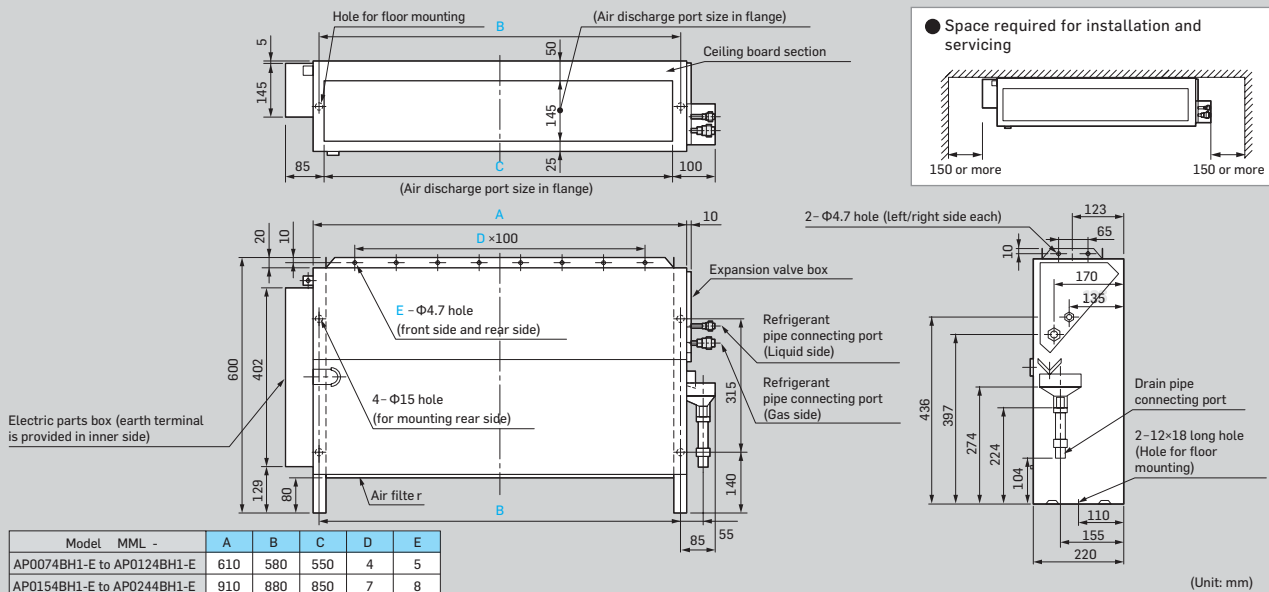

Technical specifications

Model name	MML-	AP0074BH1-E	AP0094BH1-E	AP0124BH1-E	AP0154BH1-E	AP0184BH1-E	AP0244BH1-E	
Cooling/Heating capacity*1	(kW)	2.2/2.5	2.8/3.2	3.6/4.0	4.5/5.0	5.6/6.3	7.1/8.0	
Electrical characteristics	Power requirements	1-phase 50Hz 230V (220-240V) / 1-phase 60Hz 220V (Separate power supply for indoor units required.)						
	Power consumption 50 Hz/60 Hz	(kW)	0.056/0.058		0.090/0.096		0.095/0.110	
External dimensions	Height	(mm)	600					
	Width	(mm)	745			1,145		
	Depth	(mm)	220					
Total weight	(kg)	21				29		
Fan unit	Standard air flow (High/Mid/Low)	(m ³ /h)	460/400/300		740/600/490		950/790/640	
	Motor output	(w)	19		70			
Connecting pipe	Gas side	(mm)	ø9.5		ø12.7		ø15.9	
	Liquid side	(mm)	ø6.4				ø9.5	
	Drain port (nominal dia.)	(mm)	20 (Polyvinyl chloride tube)					
Sound pressure level*2 (High/Mid/Low)	(dB(A))	36/34/32			42/37/33			
Sound power level (High/Mid/Low)	(dB(A))	54/52/50				60/55/51		

Note 1 : The capacities are measured under the conditions specified by JIS B 8615 based on the reference piping.

Note 2 : The sound level are measured in an anechoic chamber in accordance with JIS B 8616.

Normally, the values measured in the actual operating environment become larger than the indicated values due to the effects of external sound.

Note : Rated conditions Cooling : Indoor air temperature 27°C DB/19°C WB, Outdoor air temperature 35°C DB

Heating : Indoor air temperature 20°C DB, Outdoor air temperature 7°C DB/6°C WB

Fresh air intake indoor unit type

MMD-AP*HFE**



Air controller for fresh-air intake

Outside static pressure maximum 230 Pa (50 Hz unit of 5 HP capacity). Use of high-performance filter provides more comfortable room environment. Introduces outdoor air at a temperature close to that of the indoor air. Primary processing of fresh outdoor air.

NOTE: The fresh air intake indoor unit is an air conditioner provided to handle the fresh air load and is not to control the room temperature. For correspondence to the load of the indoor air controller, set an air conditioner separately.

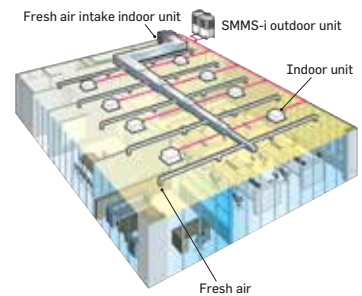

Remote controller



RBC-ASC11E
RBC-ASC11UE



RBC-AMS55E-EN/ES
RBC-AMSU51-EN/ES

Technical specifications

Model name	MMD-	AP0481HFE	AP0721HFE	AP0961HFE
Cooling/Heating capacity (Note 1)	(kW)	14.0/8.9	22.4/13.9	28.0/17.4
Electrical characteristics	Power requirements	1-phase 50 Hz 230 V (220–240 V)/60 Hz 220 V		
	Power consumption 50 Hz/60 Hz (kW)	0.28/0.34	0.45/0.55	0.52/0.65
External dimensions	Height (mm)	492		
	Width (mm)	892	1,392	
	Depth (mm)	1,262		
Total weight	(kg)	93	144	
Fan unit	Standard air flow (m ³ /h)	1,080	1,680	2,100
	Motor output (kW)	0.160	0.160×2	
	External static pressure 50 Hz/60 Hz (w)	170-210-230 / 115-215-260	140-165-180 / 150-210-235	160-190-205 / 80-180-220
	Air flow limit Lower limit/Upper limit (mm)	756/1,188	1,176/1,848	1,470/2,310
Connecting pipe	Gas side (mm)	ø15.9	ø22.2	
	Liquid side (mm)	ø9.5	ø12.7	
	Drain port (mm)	25		
Sound pressure level*2 (Note 2) (High/Mid/Low) (dB(A))		45/43/41	46/45/44	
Sound power level (High/Mid/Low) (dB(A))		60/58/56	61/60/59	
Operation Range	Cooling (Note 3) (°C)	5 – 46		
	Heating (Note 4) (°C)	–5 – 46		

* The setting temperature is 16 – 27°C (standard FCU...18 – 29°C).

* An optional humidifier is not available with fresh air intake indoor unit.

* Height difference between fresh air intake indoor units must be within 0.5 m. Height difference between fresh air intake indoor unit and standard FCU must be within 30 m.

NOTE 1 Rated conditions Cooling: Outdoor air temperature 33°C DB/28°C WB setting temperature 18°C
Heating: Outdoor air temperature 0°C DB/–2.9°C WB setting temperature 25°C

NOTE 2 Normally, the values measured in the actual operating environment become large than the indicated values due to the effects of external sound.

NOTE 3 * When supply air temperature is "setting temperature + 3°C" or less, fresh air intake indoor unit operates as FAN mode.

* When supply air temperature is 19°C or less, Fresh Air Intake Indoor unit operates as FAN mode.

NOTE 4 * When supply air temperature is "setting temperature –3°C" or over, fresh air intake indoor unit operates as FAN mode.

Use Conditions

• In COOL mode, if temperature of the fresh air is below the set temperature, by +3°C, the unit automatically switches to FAN mode. When temperature of the fresh air is below 19°C, FAN mode is selected irrespective of the set temperature.

• In HEAT mode, if temperature of the fresh air is above the set temperature by -3°C, FAN status is automatically selected.

When temperature of the fresh air is above 15°C, FAN mode is automatically selected regardless of the setup temperature.

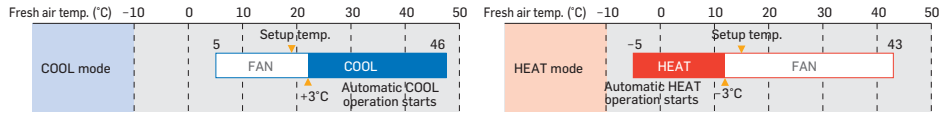

Operable mode and discharge temperature setup range

Operation mode	At shipment from factory	Setup range
COOL	18°C	16 to 27°C
HEAT	25°C	16 to 27°C

MMD-AP0481HFE to AP0961HFE

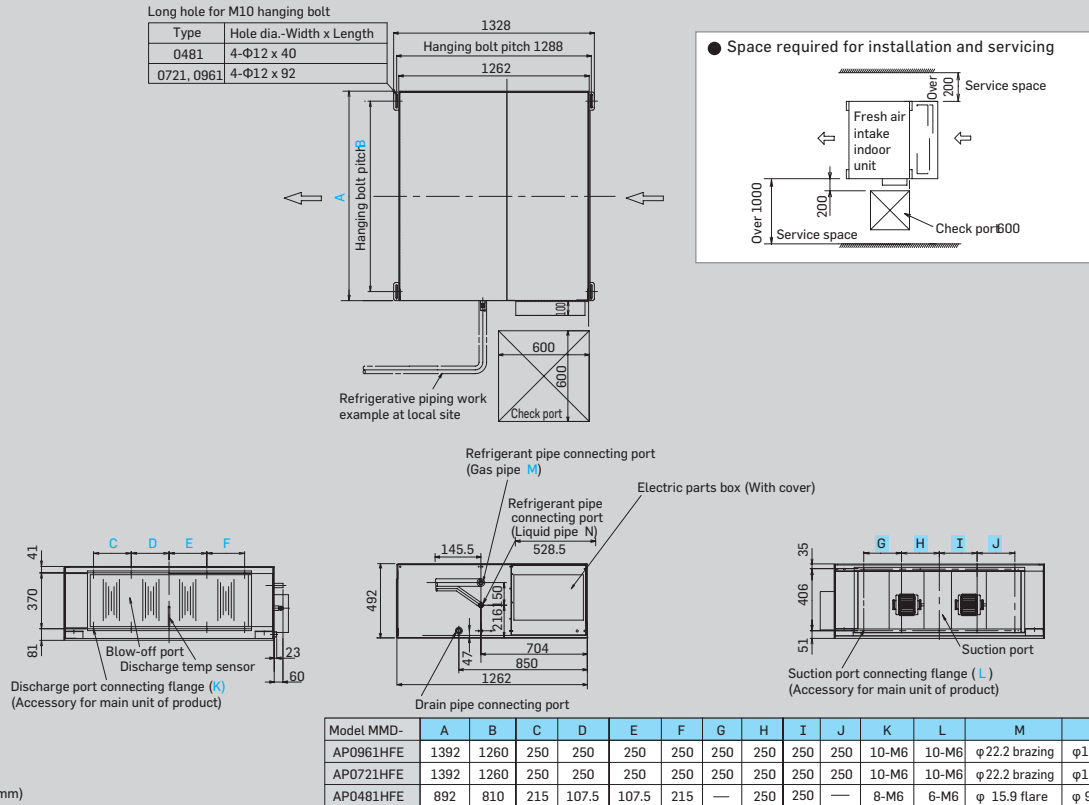

Options

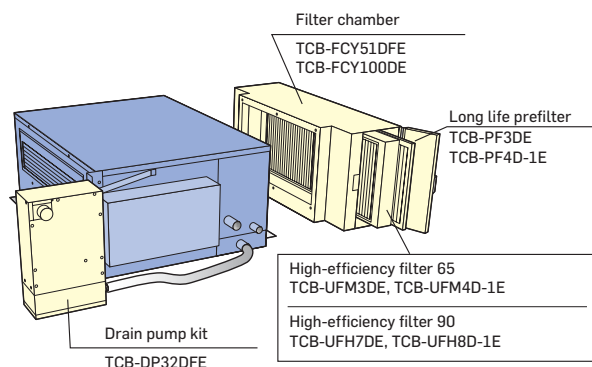

Indoor unit accessories

Indoor unit	Parts Name	Model Name	Applied Model	Notes	Remarks
4-way air discharge cassette type	Ceiling panel	RBC-U31PGP(W)-E	MMU-AP***4HP1-E	Required accessory	
	Fresh air inlet box	TCB-GB1602UE		For fresh air intake by using the knockout hole of fresh air filter chamber. (dia.=100 mm)	Use with TCB-GFC1602UE
	Fresh air filter chamber	TCB-GFC1602UE		For fresh air inlet box	
	Auxiliary fresh air flange	TCB-FF101URE2		For easy fresh air intake by using the knockout hole of indoor unit. (dia.=100 mm)	
	Spacer for height	TCB-SP1602UE		Height=50 mm	
	Air discharge direction kit	TCB-BC1602UE		Air direction charge by cutting off air discharge port (3 pcs.)	
Compact 4-way cassette (620 x 620) type	Ceiling panel	RBC-UM21PG(W)E	MMU-AP***7MH-E	Required accessory	
	Auxiliary fresh air flange	TCB-FF101URE2		For easy fresh air intake by using the knockout hole of indoor unit. (dia.=100 mm)	
2-way air discharge cassette type	Ceiling panel	RBC-UW283PG(W)-E	MMU-AP0072 to 0152WH1	Required accessory	
		RBC-UW803PG(W)-E	MMU-AP0182 to 0302WH1		
		RBC-UW1403PG(W)-E	MMU-AP0362/0482/0562WH1		
	Super long life filter	TCB-LF283UW-E	MMU-AP0072 to 0152WH1	Dust collecting effect: 50% (Weight method)	Use with TCB-FC283UW-E
		TCB-LF803UW-E	MMU-AP0182 to 0302WH1		
		TCB-LF1403UW-E	MMU-AP0362/0482/0562WH1		
	Filter chamber	TCB-FC283UW-E	MMU-AP0072 to 0152WH1	For super long life filter	
		TCB-FC803UW-E	MMU-AP0182 to 0302WH1		
TCB-FC1403UW-E		MMU-AP0362/0482/0562WH1			
Auxiliary fresh air flange	TCB-FF151US-E	MMU-AP***2WH1	For fresh air intake by using the knockout hole of indoor unit.		
1-way air discharge cassette type	Ceiling panel	RBC-UY136PG	MMU-AP***4YH1-E	Required accessory	
		RBC-US21PGE	MMU-AP***4SH1-E	Required accessory	
	Front air discharge unit	TCB-BUS21HWE			
	Auxiliary fresh air flange	TCB-FF101URE2		For easy fresh air intake by using the knockout hole of indoor unit. (dia.=100 mm)	
Concealed duct type	Spigot shaped flange	TCB-SF56C6BPE		MMD-AP0076 to 0186BHP1-E	
		TCB-SF80C6BPE	MMD-AP0246/0276/0306BHP1-E		
		TCB-SF160C6BPE	MMD-AP0366/0486/0566BHP1-E		
Concealed duct high static pressure type	Long Life Filter Kit	TCB-LK801D-E	MMD-AP0186/0246/0276HP1-E		
		TCB-LK1401D-E	MMD-AP0366/0486/0566HP1-E		
		TCB-LK2801DP-E	MMD-AP0726/0966HP-E		
	Spigot Shaped Flange	TCB-SF80C6BPE	MMD-AP0186/0246/0276HP1-E		
		TCB-SF160C6BPE	MMD-AP0366/0486/0566HP1-E		
	Auxiliary fresh air flange	TCB-FF151US-E	All Models		
	High-efficiency filter 65	TCB-UFM3DE	MMD-AP0726/0966HP-E	Dust collecting effect: 65%(NBS Colorimetric method)	
	High-efficiency filter 90	TCB-UFH7DE	MMD-AP0726/0966HP-E	Dust collecting effect: 90%(NBS Colorimetric method)	
	Long life prefilter	TCB-PF3DE	MMD-AP0726/0966HP-E	Dust collecting effect: 50%(Weight method)	
Filter chamber	TCB-FCY100DE	MMD-AP0726/0966HP-E	For high-efficiency filter or long life prefilter		
Drain pump kit	TCB-DP40DPE	MMD-AP0726/0966HP-E	Stand-up 330 mm or less (from bottom face of ceiling)		
Slim duct type	Auxiliary fresh air flange	TCB-FF101URE2	MMD-AP***4SPH1-E	For fresh air intake by using the knockout hole of indoor unit. (dia.=100)	
Ceiling type	Drain pump kit	TCB-DP31CE	MMC-AP0158/0188HP-E	Stand-up 600 or less (from bottom face of ceiling)	Use with TCB-KP13CE
			MMC-AP0248 to 0568HP-E		Use with TCB-KP23CE
	Elbow piping kit	TCB-KP13CE	MMC-AP0158/0188HP-E	Needed when drain pump kit is used	
		TCB-KP23CE	MMC-AP0248 to 0568HP-E		

Accessory for 4-way air discharge cassette type: combination pattern	1	2	3	4	5	6
	Ceiling panel	Fresh air inlet box + Fresh air filter chamber	Fresh air filter chamber	Auxiliary fresh air flange	Spacer for height adjustment	Air discharge direction kit
1 Ceiling panel		OK	OK	OK	OK	OK
2 Fresh air inlet box + Fresh air filter chamber	OK			OK	-	OK
3 Fresh air filter chamber	OK			OK	OK	OK
4 Auxiliary fresh air flange	OK	OK	OK		OK	OK
5 Spacer for height adjustment	OK	-	OK	OK		OK
6 Air discharge direction kit	OK	OK	OK	OK	OK	

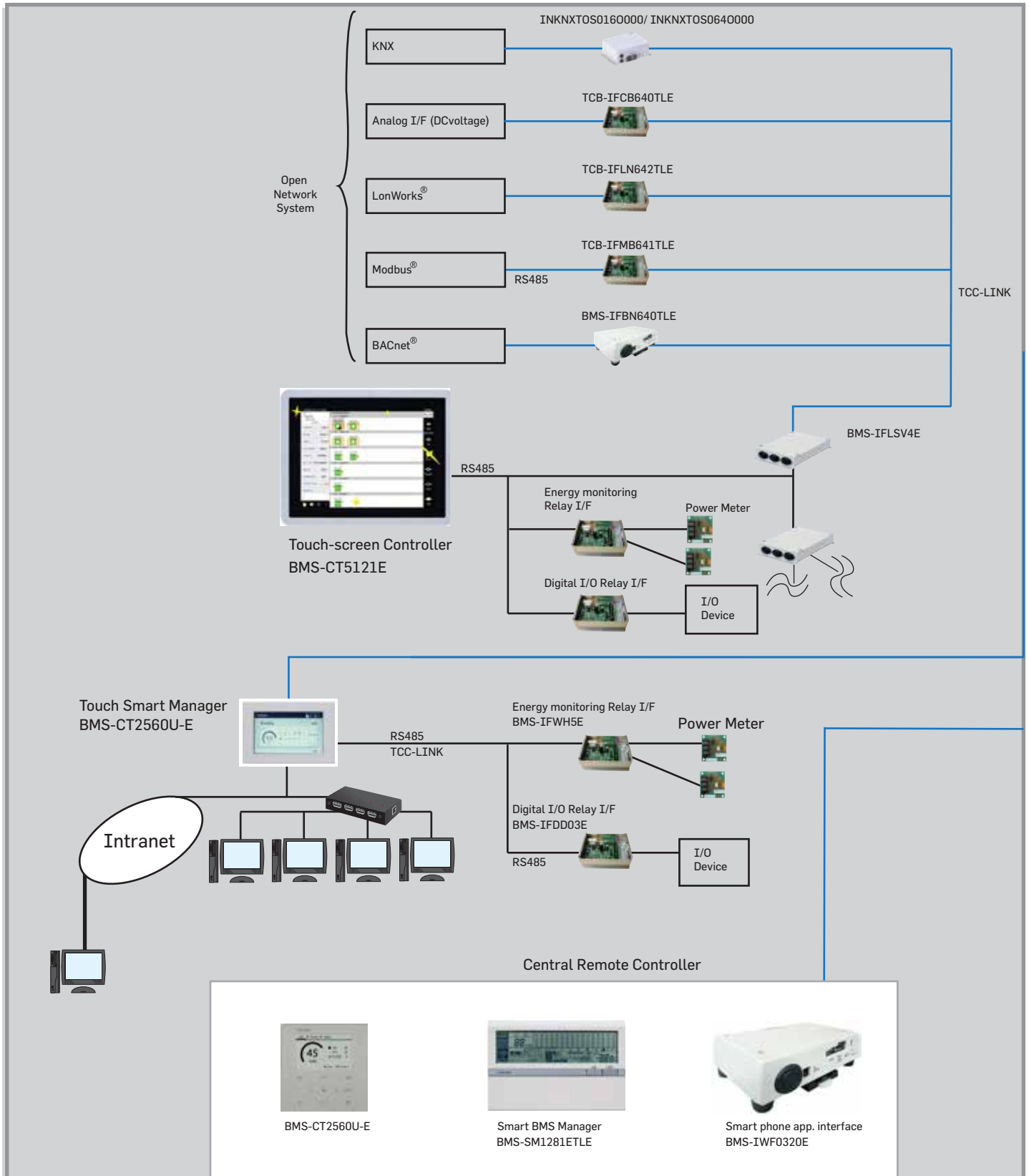

1. LonWorks® : Registered trademark by Echelon corporation.
2. BACnet® : ANSI/ASHRAE 135-1995, A data Communication Protocol for Building Automation and Control Network.
3. Modbus® : Registered trademark by Schneider E.
4. KNX® : Registered trademark by knx.org

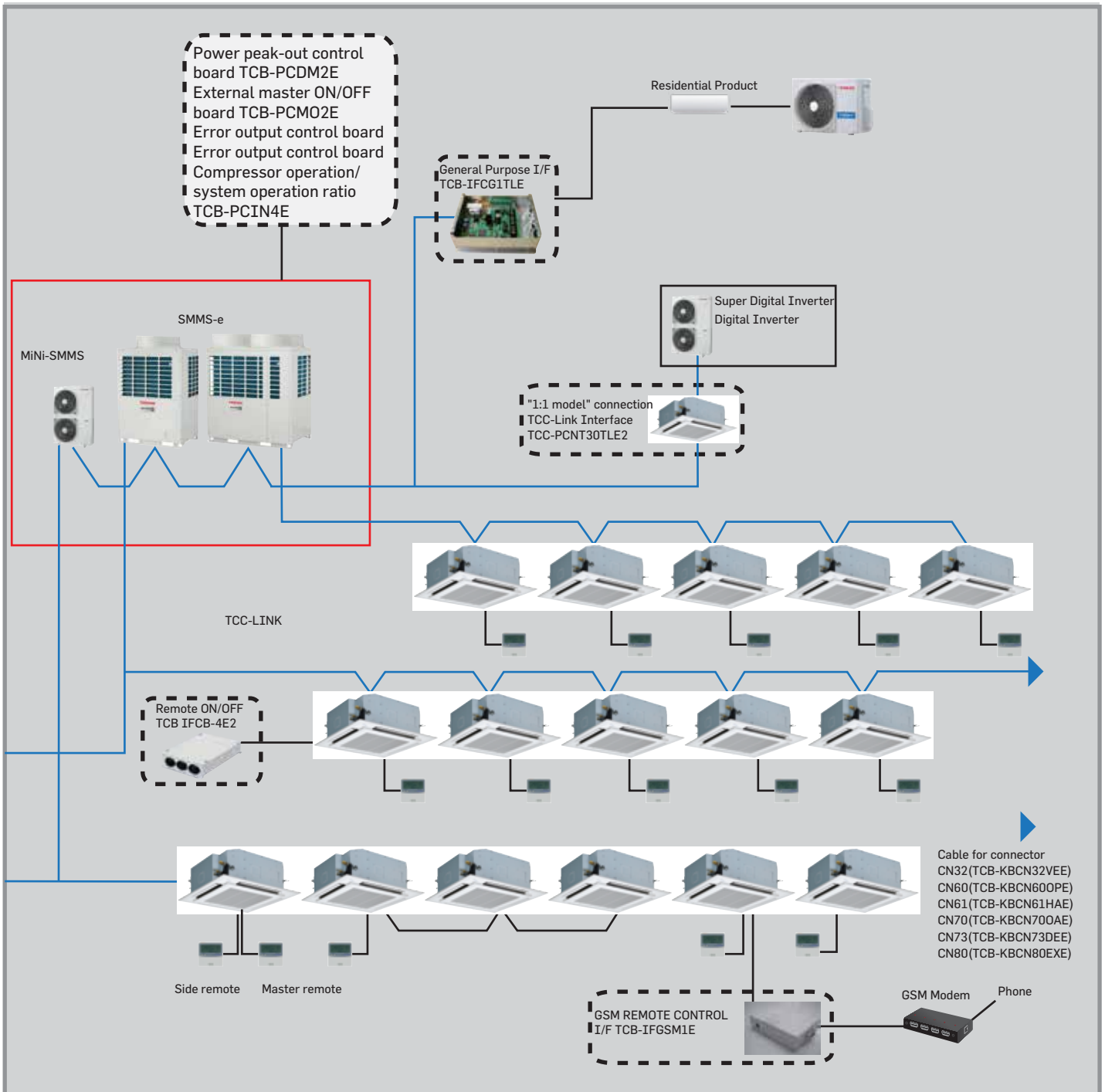

Wire remote controller/wireless remote controller



*ESMA (UAE) Compliance

Wired remote controller



Compact Remote controller
RBC-ASC11E
RBC-ASC11UE

The RBC-ASC11E and RBC-ASC11UE local compact remote controller with LCD backlight display features simpler control keys for easier use.

Key Features:

- Simple keys; Menu, Timer; Up & Down, On/Off
- Large LCD display
- Mode
- Fan Speed
- Louvre Direction
- Timer setting
- Fault diagnosis
- DN code setting
- Room temperature display always available
- Remote TA sensor available in controller.



Simple wired remote controller
RBC-AS41E

Key Features:

- Start/Stop
- Temperature setting
- Air flow changing
- Check code display



Remote controller with weekly timer
(7-day timer function)
RBC-AMS41E
RBC-AMS41E-ME*

Key Features:

- Clock display
- Schedule timer: Possible to program schedule timer (7-day timer) function
- Possible to program 8 functions for each day of the week.

* The following items can be set in program: operation time, operation start/stop, operation mode, temperature setting, restriction on button operation.



Lite-Vision plus Remote Controller

RBC-AMS55E-EN/ES
RBC-AMSU51-EN/ES

Wired remote controller with a built in 7-day timer-featuring a new multi-language, LCD display with backlight, energy saving options and a return back function.

- Possibility to set and display the room name to easily set-up and monitor the working parameter.
- New modern and desirable controller design with menu driven display.
- Save mode by schedule timer to optimise energy consumption.
- Room temperature display always available.
- Two "Hot Keys" (F1, F2) for easy operation of air conditioner functions.
- Easy to read layout including display of indoor unit model name and serial number.
- Built-in backup power. Settings are kept in memory up to 72 hours in case of power failure.
- Remote TA sensor available in controller.
- Can be connected to a single indoor unit or a group of up to 8 indoor units.

*ESMA (UAE) Compliance

Wireless remote controller



Wireless remote controller kit & sensor unit
(receiver unit)

- Start/Stop
- Changing mode
- Temperature setting
- Airflow changing
- Timer function

Either "ON" time or "OFF" time or "CYCLIC" can be set how many 30 min. later ON or OFF is operated.

- Control by 2 remote controllers is available. Two wireless remote controllers can operate one indoor unit. The indoor unit can then be operated separately from the two different locations.
- Check code display

* The wireless remote control cannot be connected to concealed duct high static pressure type



RBC-AX33CE
Integral receiver
(For ceiling) (MMC-AP***8HP-E)
(MMU-AP***4SH1-E)



RBC-AX32U(W)-E
Integral receiver (For 4-way air
discharge cassette)
(MMU-AP***4HP1-E)



RBC-AX32UW(W)-E
Integral receiver (For 2-way air
discharge cassette)
(MMU-AP***2WH1)



TCB-AX32E2
RBC-AXU31-E

Stand alone receiver (For 4-way air discharge cassette, compact 4-way cassette (600 x 600), 2-way air discharge cassette, ceiling, concealed duct standard, slim duct, floor standing cabinet, floor standing, 1-way discharge cassette (MMU-AP ***4YH1-E/SH1-E)

Central remote controller



Central remote controller
TCB-SC640U-E

The TCB-SC640U-E 64-way central controller is TOSHIBA's standard central control solution and can be connected to up to 64 indoor units via the TCC-Link central control network. Indoor units can be controlled in terms of: individual indoor unit/group, all units in a zone (1 to 10), and all units connected.



Advance central controller - Smart Manager
BMS-SM1281ETLE

The Smart Manager has the same hardware Control Function as the BMS-CM1280TLE Controller, but also has the ability of control from a Local Area Network and, with the use of an additional Interface, is capable of Energy Monitoring and Report Creation Functions. This controller is ideal where advanced control, Energy Monitoring, advanced scheduling or access to individual Air Conditioners is required from networked computer systems.

Web Browser Control Software Features:

- List View available -Displays all Indoor Units from one screen
- Set View available – Shows Basic Indoor Unit settings on main screen g
- Advanced Operation and Master schedule functions available
- Up to 4 Concurrent users can be connected
- Up to 32 User accounts can be programmed with different levels of access (at least 1 must be administrator level)



Smart Phone Application Interface



BMS-IWF0320E

The BMS-IWF0320E is a versatile interface for Toshiba air conditioning units that enables monitoring and controlling air conditioners (up to 32) using smart phone application. You can change the details of the settings, turn the air conditioners and off, and monitor the operation status, settings status, and error incident status of the air conditioners. Air conditioners are divided into hierarchies based on floors and can be positioned and registered for each floor. Controls for the air conditioners can be set per air conditioner unit.

Scheduling operations:

You can control the schedule for the air conditioners' operation in weekly units. The items that you can set are almost the same as normal setting details, including starting and stopping operation, operation modes, operation temperature settings, air speed, and air direction. You can also display and check the schedule you set as a graph.



Administrator functions and user privilege functions:

You can set either administrator privileges or user privileges for each user ID. Users with administrator privileges can use all functions. Users with user privileges cannot use some functions.

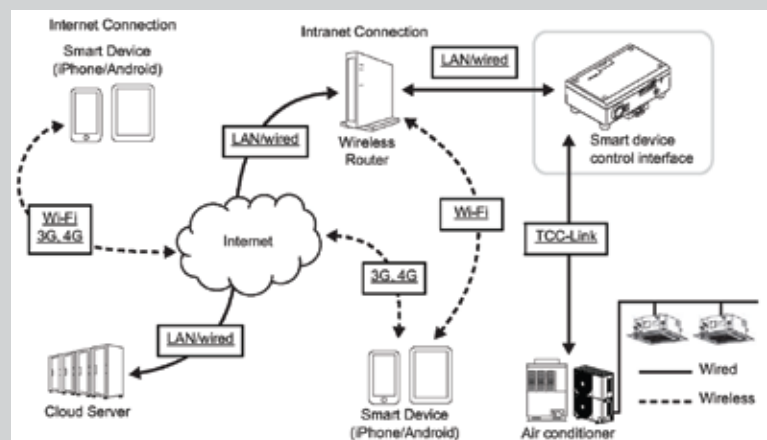

This application is confirmed to operate with the following manufacturer's models:

- Apple iPhone 7, iPhone 7 Plus, iPad - Operating System (iOS) Version 9.x, 10.x
- Sony Xperia XZ, Xperia XA1 Ultra - Operating System (Android) 5.x, 6.x, 7.x
- Samsung Galaxy S7, Galaxy S8, Galaxy Tab A10.1, Galaxy Tab S3 9.7, Galaxy Tab A7.0 - Operating System (Android) 5.x, 6.x, 7.x

Advance control systems

Touch Smart Manager



Advance central controller - Touch Smart Manager
BMS-CT2560U-E

The Touch Screen Controller offers energy monitoring, schedule programming and full function control of all connected indoor units. This controller is ideally suited to any small or large installation where energy monitoring functions is required. It enables control for each individual indoor unit and is capable of providing information from the indoor unit settings and malfunction check codes. The Touch Screen is connected to the air conditioning control network directly by relay interfaces.

Features

- Compact size & white design for perfect integration in every interiors.
- Outstanding control experience with 7" capacitive touch screen.
- Developed for every kind of system up to 128 indoor units.
- Easy installation with direct connection to TCC link Toshiba protocol.
- Interlocking with external device
 - 8 Inputs (Built-in)
 - No-voltage contact (A Pulse or static) for Power Meter Pulse input.
 - No-voltage contacts (Interlock)
 - 4 Outputs (Built-in)
 - External device control
- Expansion Module are available for addition I/O requirement.
 - BMS-IFWH5E – Energy Monitoring Interface
 - BMS-IFDD03E -Digital Input/Out Interface.
- Monitoring of data trending through the smart manager Touch screen

Control Wiring

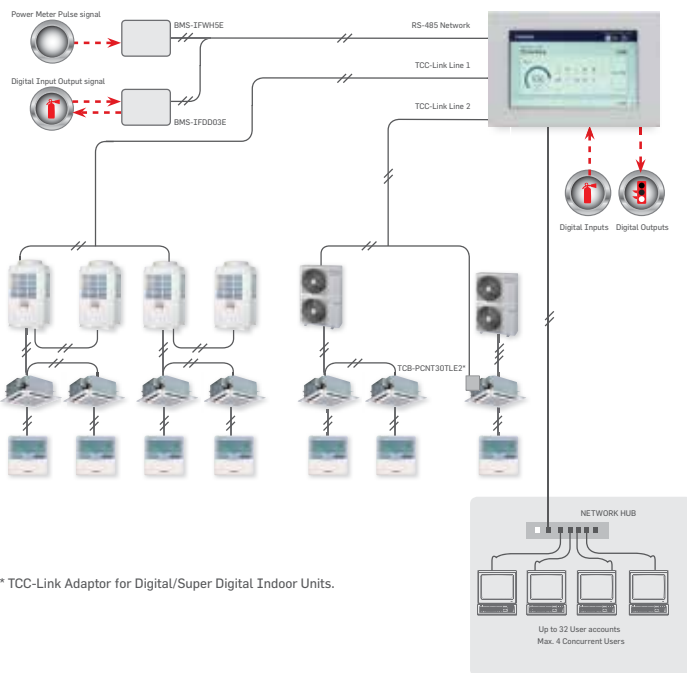

* TCC-Link Adaptor for Digital/Super Digital Indoor Units.



Display the total electric power on a daily/monthly basis on a graph.



Display operating time and sensor information.

Equipment List

Device	Number of pieces	Description
BMS-CT2560U-E	1	Up to 128 indoor unit can be connected to Touch Smart Manager
BMS-IFDD03E	Up to 4 Boards	Interface for Digital Input & Outputs. Can connect up to 8 Power Meters per Board (Optional)
BMS-IFWH5E	Up to 4 Boards	Interface for Power Meter (Energy Monitoring Option only)

Locally Procured Item

Device	Number of pieces	Description
Power Meter		Digital Energy Meter with Pulse Output (Energy Monitoring Option only)
PC		For Operation Monitoring
Network Hub		For LAN Connection.



Energy consumption history (days)

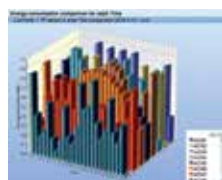

Energy consumption comparison



Alarm list

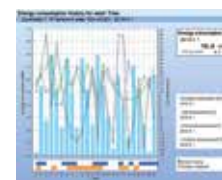

Energy consumption history (Hours)

Advance control systems

Touch-screen controller



Touch-screen Controller
BMS-CT5121E



Touch-screen controller

Using the touch-screen controller provides a clear display and enables easy operation. A maximum of 512 units are controllable using the one-touch controller.

Function

- Operation monitoring
- Operation control
- Operation Schedule
- Error Code
- Alarm List
- Energy monitoring/Billing
- Digital I/O Signal Control
- Web function
- Email alert
- Graphical report
- Building layout



Up to 8
Relay Interface BMS-IFLSV4E
For TCS-NET



Up to 8
Relay Interface BMS-IFWH5E
For Energy Monitoring
(Optional)



Up to 8
Relay Interface BMS-IFDD03E
For Digital I/O
(Optional)

Control Wiring

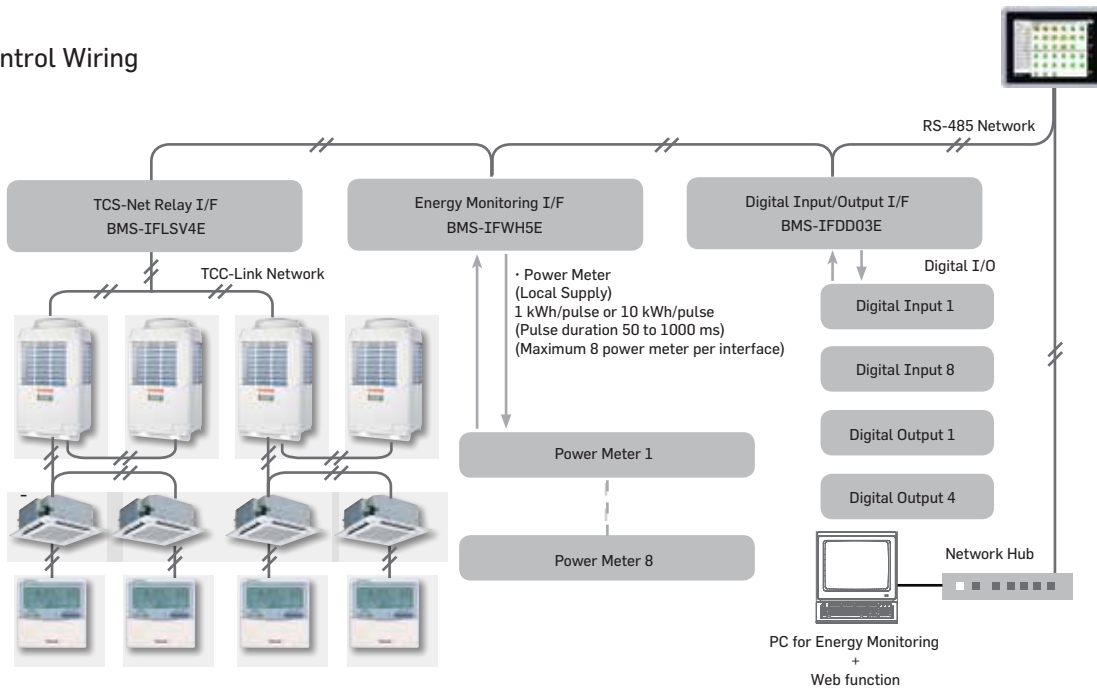

Equipment List

Device	Number of pieces	Description
BMS-CT5121E	1	Up to 512 indoor units can be connected to Touch controller
BMS-IFLSV4E	Up to 8 Boards	Relay Interface for up to 64 indoor units
BMS-IFDD03E	Up to 8 Boards	Interface for Digital Input & Outputs. Can connect up to 8 Power Meters per Board (Optional)
BMS-IFWH5E	Up to 8 Boards	Interface for Power Meter (Energy Monitoring Option only)

Locally Procured Item

Device	Number of pieces	Description
Power Meter		Digital Energy Meter with Pulse Output (Energy Monitoring Option only)
PC		For Operation Monitoring
Network Hub		For LAN Connection.

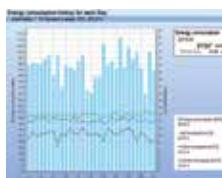

Energy consumption history (days)

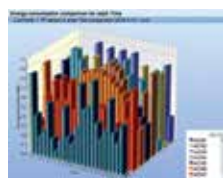

Energy consumption comparison



Alarm list



Energy consumption history (Hours)

BACnet®



BACnet/IP Interface
BMS-IFBN640TLE

BACnet Interface

The Toshiba BMS-IFBN640TLE BACnet Interface can be connect to the TCC-Link Central Control Network to enable control of the attached Air Conditioner product from a BACnet Building Management System.

- Maximum 64 Indoor Units/Groups and 16 Outdoor Systems can be connected to a single Interface.
- TCB-PCNT30TLE2 Network adaptor required for connection of DI/SDI to BACnet System.

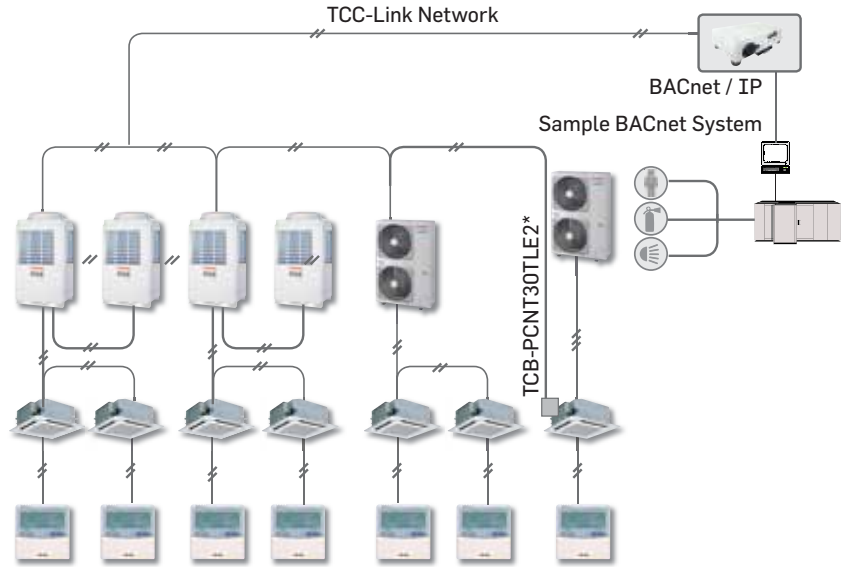

* TCC-Link Adaptor for Digital/Super Digital Indoor Units.

KNX®



KNX/TP Interface
INKNXTOS0160000
INKNXTOS0640000

KNX Interface

The KNX interface manages the Toshiba VRF System air conditioning system as a KNX® device to communicate with the customer's Home automation.

Accessible to 64 units per one ,

Signals and provides the following functions:

- ON/OFF
- Mode: cool/heat/fan
- Air flow and fan speed
- Temperature setting
- Filter reset

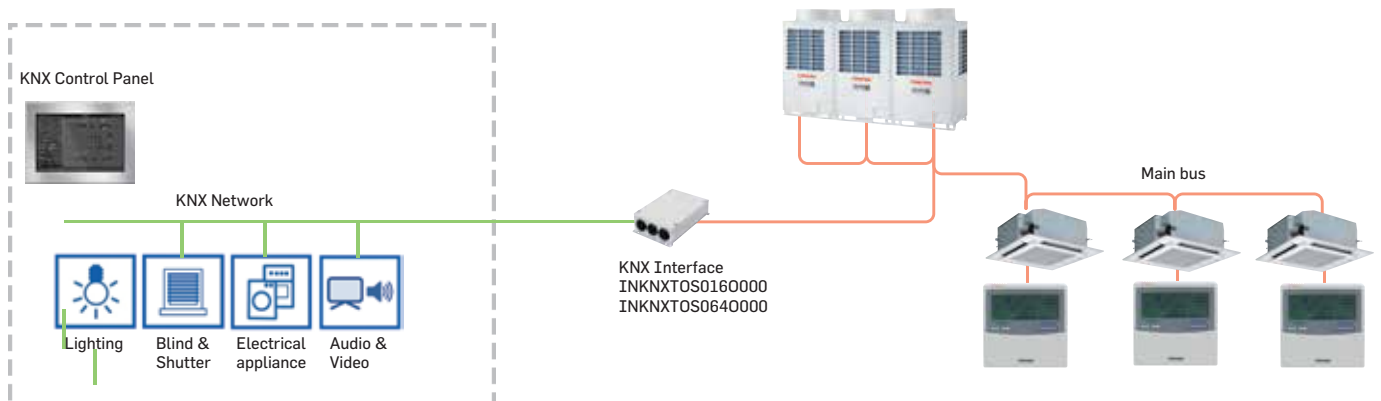

Open network systems

LonWorks®



LonWorks Interface
TCB-IFLN642TLE

LonWorks Interface

The LonWorks interface manages the SMMS-i air conditioning system as a Lon device to communicate with the customer's Building Management System and to monitor operational status. A maximum of 64 units are controllable per interface.

SNVT signal

Signals and provides the following functions:

Object signals command

- ON/OFF
- Mode: cool/heat/fan
- Temperature setting
- Central/local

Monitoring

- ON/OFF
- Mode
- Cool/heat/fan/failure
- Temperature setting
- Room temperature
- Central/local, etc.

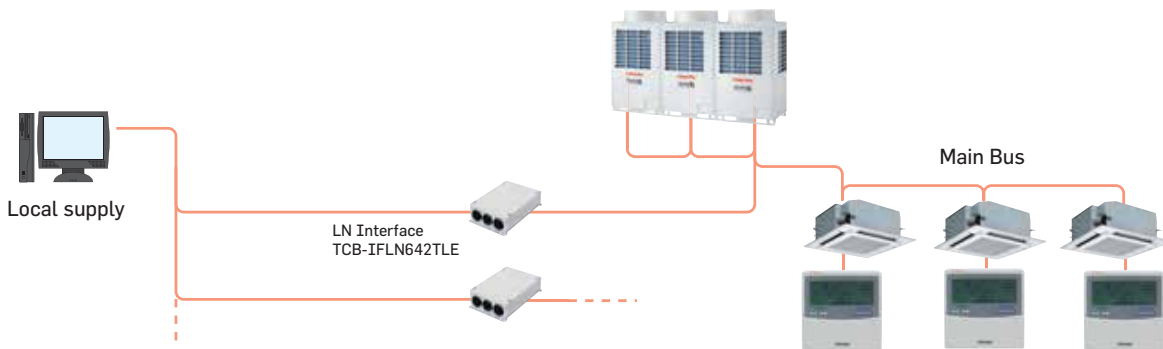

Modbus®



Modbus Interface
TCB-IFMB641TLE

Modbus Interface

The Modbus® interface manages the Toshiba VRF System air conditioning system as a Modbus® device to communicate with the customer's Building Management System. Accessible to 64 units per one TCB-IFMB641TLE, 15 TCB-IFMB641TLEs on one Modbus® Master (prepared by user).

Signals and provides the following functions:

- ON/OFF
- Mode: cool/heat/fan
- Air flow/Louver setting
- Temperature setting
- Filter reset
- Accumulated operation time, etc.

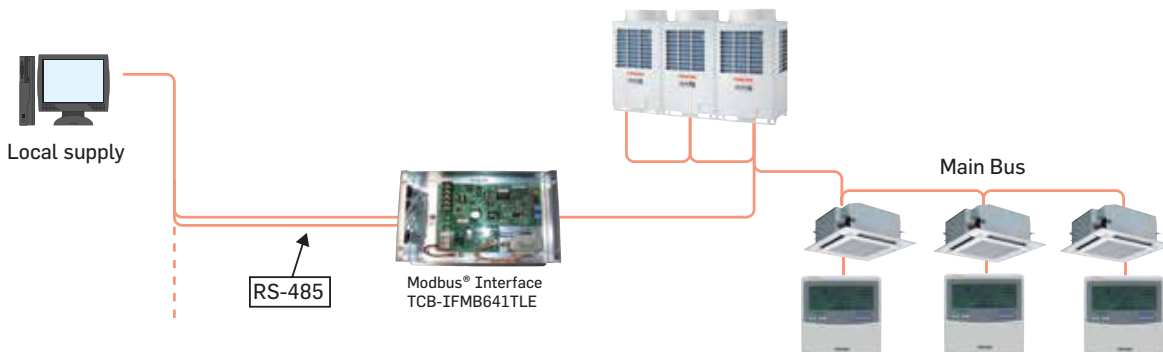

1. LonWorks®: Registered trademark Echelon corporation

2. BACnet®: ANSI/ASHRAE 135-1995, A data Communication Protocol for Building Automation and Control Networks.

3. Modbus® is a registered trademark of Schneider E.

VRF DX COIL INTERFACE

VRF DX COIL INTERFACE - AHU APPLICATION

VRF DX-coil interface is suitable for AHU with the DX Coil combined with TOSHIBA VRF outdoor unit . VRF Outdoors's capacity control using DX Kit PCB based on the return air temperature sensor.

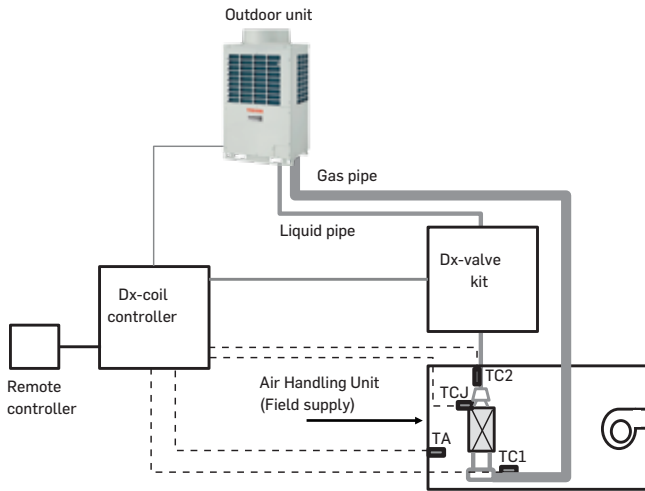

J - Series	
TCB-IFDTA201E	VRF DX COIL CONTROLLER
RBM-A101VAE	VRF DX COIL VALVE KIT (22.4kW,28kW)
RBM-A201VAE	VRF DX COIL VALVE KIT (44.8kW,50.4kW,56kW)

Notes:

- AHU & AHU's Stater panel (Field supply)
- Wired remote control (optional for J-series).

VRF DX COIL INTERFACE - FAHU APPLICATION

VRF DX-coil interface (DDC type) is suitable for FAHU with the DX Coil combined with TOSHIBA VRF outdoor unit . VRF Outdoors's capacity control using DDC (Field Supply) using 0-10V signal based on the supply air temperature sensor (Field Supply) .

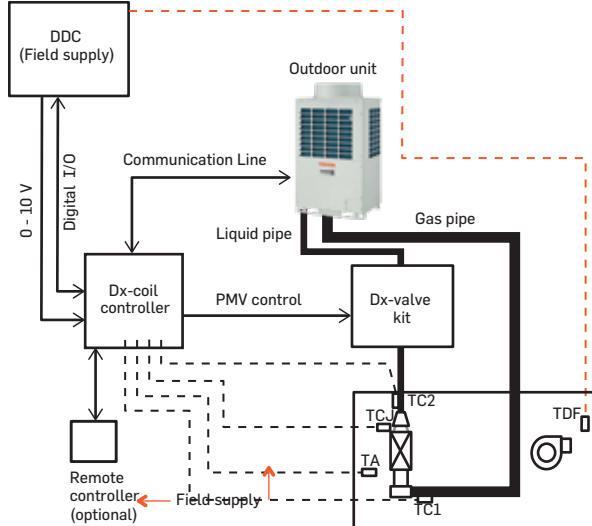

- TA : Suction air temperature sensor
 TCJ, TC1, TC2 : Evaporator temperature sensor
 TDF : AHU discharge air temperature sensor

J - Series	
TCB-IFDDC201E	VRF DX COIL CONTROLLER (0-10V AHU)
RBM-A101VAE	VRF DX COIL VALVE KIT (22.4kW,28kW)
RBM-A201VAE	VRF DX COIL VALVE KIT (44.8kW,50.4kW,56kW)

Notes:

- AHU & AHU's Stater panel (Field supply)
- DDC control panel (Field supply) is mandatory for operation.

Control Devices

Model Number	Reference	Description	Used with
RBC-AMT32E RBC-AMTU31-E	Wired Remote Controller	Main wired remote controller	VRF and VRF Air-to-air heat exchangers with (DX coil) indoor units
RBC-AS41E	Simplified Wired Remote Controller	As above but designed for hotel and domestic applications	VRF and VRF Air-to-air heat exchanges with (DX coil) indoor units
NRC-01HE	Wired Remote Controller	Wired remote controller for Air-to-air heat exchanger, including with DX coil and humidifiers models	New Air-to-air heat exchangers and Air-to-air heat exchangers with DX coil
RBC-ASC11E RBC-ASC11UE	Compact remote	Wired remote	VRF and VRF Air-to-air heat exchangers with (DX coil) indoor units
RBC-AMS41E RBC-AMS41E-ME*	Remote controller with schedule timer	Enables to control indoor unit operation with schedule timer (7-days) allowing to program 8 functions/day + clock display	VRF and VRF Air-to-air heat exchangers with (DX coil) indoor units
RBC-AMS55E-EN/ES RBC-AMSU51-EN/ES	Lite-Vision plus Remote Controller	Local Controller with Multi-Language LCD display, a built-in 7-Day timer, Energy Saving options and return back function. EN =English, Italian, Polish, Greek, Russian, Turkish. ES = English, Spanish, Portuguese, French, Dutch, German	VRF and VRF Air-to-air heat exchangers with (DX coil) indoor units
RBC-AX33CE	Infra-red Remote Kit	Wireless remote controller	All ceiling units and one-way cassettes (SH series)
TCB-AX32E2 RBC-AXU31-E	Infra-red Remote Kit	Wireless remote controller	All other units (including compact 4-way cassette)
RBC-AX32UW(W)-E	Wireless remote unit kit	Wireless remote unit kit for 2-way cassette	2-way-cassette MMU-AP***2WH
RBC-AX32U(W)-E	Wireless remote unit kit	Wireless remote unit kit for 4-way cassette	RBC-U31PGP(W)-E & RBC-U31PGXP(W)-IN1 panels for 4-way cassette indoors.
RBC-AX32UM(W)-E	Wireless remote unit kit	Wireless remote unit kit for compact 4-way cassette	With RBC-UM21PG(W)E panels for compact 4-way cassette indoors.
TCB-SIR41UM-E	PIR sensor	Occupancy sensor	With RBC-UM21PG(W)E panels for compact 4-way cassette indoors.
TCB-TC41LE TCB-TC41U-E	Remote temperature sensor	Remote temperature sensor for cassette & duct	All VRF
TCB-IFCB5-PE	Remote location On / Off Control Box	Enables remote location On / Off control	All VRF indoor units.
BMS-IWF0320E	Smart phone application interface.	Enables full control of up to 32 indoor units	All VRF indoor units.
TCB-SC640U-E	64 way control	Enables full control of up to 64 indoor units	All VRF indoor units.
BMS-SM1281ETLE	Smart Manager with Data analyzer	Enables full control of up to 128 indoor units with Energy Monitoring and Advanced Control Options	All VRF indoor units.
BMS-CT2560U-E	Touch Smart Manager	Enables full control of up to 128 indoor units	All VRF indoor units.
BMS-CT5121E	Touch Screen Controller	Enables full control of up to 512 indoor units, ML	All VRF indoor units.
BMS-IFLSV4E	TCS-Net Relay Interface	Relay for integration to TCS-Net	Bacnet gateway, Touch-screens & Web based controller
BMS-IFDD03E	Digital I/O interface	Enable digital input/output interlock signal	Applicable for Touch screen controller and Smart Manager
BMS-IFWH5E	Energy monitoring relay interface	Energy monitoring relay interface	Touch screen controller, Compliant manager, Web based controller, Smart Manager
BMS-IFBN640TLE	BACnet	BACnet interface	Up to 64 indoor unit. All VRF indoor unit.
TCB-IFLN642TLE	Lonworks® Gateway	Allows control of 64 indoor units from a Lonworks based BMS	All VRF indoor units
TCB-IFMB641TLE	Modbus Interface	Allows control of 64 indoor units from a Modbus based BMS	All VRF indoor units
INKNXTOS0160000 INKNXTOS0640000	KNX Interface	Allows control of 64 indoor units from a KNX based BMS/Home Auto machine	All VRF indoor units

*ESMA (UAE) Compliance

Model Number	Reference	Description	Used with
TCB-IFCG1TLE	General purpose interface	Enables control of A/C by the DI/DO and AI/AO	All VRF indoor units
TCB-PX30MUE	Terminal box	Steel Terminal box to connect to	TCB-PCNT30TLE2, TCB-IFCB5-PE
TCB-PX100PE	Terminal box	Plastic Terminal box to connect to	TCB-PCNT30TLE2, TCB-IFCB5-PE
TCB-IFCB-4E2	Application Control PC Board	Remote On/Off Control	All VRF indoor units.
TCB-IFCB5-PE	Application Control PC Board	Window Switch Remote On/Off control	All VRF indoor units.
TCB-PCDM4E	Application Control PC Board	Power Peak Cut Control	All VRF outdoor units.
TCB-PCMO4E	Application Control PC Board	External Master ON/OFF Control Board	All VRF outdoor units.
TCB-PCUC2E	Application Control PC Board	Input / Output Control Board	Ceiling, Floor standing and high static duct.
TCB-PCIN4E	Connectors	Error/Individual compressor Operation Output Control Board	All VRF outdoor units.
TCB-KBCN32VEE	Application Control PC Board	For CN32	All VRF indoor units.
TCB-KBCN600PE		For CN60	All VRF indoor units.
TCB-KBCN61HAE		For CN61	All VRF indoor units.
TCB-KBCN700AE		For CN70	All VRF indoor units.
TCB-KBCN73DEE		For CN73	All VRF indoor units.
TCB-KBCN80EXE		For CN80	All VRF indoor units.



Installation and the use of refrigerants not specified by Toshiba Carrier Corporation

Toshiba refrigeration and air-conditioning units are designed and manufactured on the assumption that the product is used with a specific refrigerant suitable for each unit.

We have recently seen some cases where the type of refrigerant used is different from the one originally installed in the product. Such actions may cause mechanical defects, malfunctions, failures and in some cases result in a serious safety issue. Therefore do not install any refrigerant other than the one specified by Toshiba Carrier Corporation for its respective products.

The type of the refrigerant used for each of our products is shown in the accompanying owners manual, or on the product label attached on the product itself.

Toshiba Carrier Corporation shall not assume any liability for failures, malfunctions or safety in its products if the refrigerant used is different from the one specified.



SAFETY PRECAUTIONS

For operation:

- Before use, read through the operating instructions to ensure proper use.
- Concerning the purpose for which the air conditioners are to be used
- The air conditioners presented in this catalogue are air conditioning/heating units to be used solely by general consumers.

- Do not use these air conditioners for special applications such as for the storage of food items, animals, plants, precision machines or works of art. Doing so may degrade the quality of the items.
- Do not use these air conditioners for air-conditioning applications in vehicles or ships. Doing so may cause water and/or power leakages.

Precautions for using air conditioners

Concerning the automatic defrosting unit

When the outdoor air temperature drops, frost may form on the heat exchanger of the outdoor unit. In such cases, the automatic defrosting unit will be activated, and it will take 5 to 8 minutes for the heating operation to be restored.

Concerning the air conditioner's operating conditions and their selection

(1) Avoid using the air conditioner in the following locations.

- Locations with acidic or alkaline atmospheres (locations at which highly acidic or alkaline air is directly drawn in, such as in hot springs areas from which sulfur gases are given off, or where chemicals, vinegar, exhaust air from burners, etc., are given off). The heat exchangers and other parts may become corroded.

- Locations with atmospheres filled with coolant or other machine oil or steam exhaust (such as at food preparation factories or machine plants). The heat exchangers may corrode; frost may form as a result of heat exchanger malfunction; air conditioner operating performance may be compromised or condensation may form as a result of clogged filters; plastic parts may incur damage; heat-insulation materials may become separated, etc.

(2) Before using an air conditioner in any of the following locations, consult with your dealer or a qualified contractor.

- Locations where vapors from edible oils are given off (such as in bakeries or kitchens and restaurants that use edible oils)...The air conditioner's operating performance may be compromised or condensation may form as a result of clogged filters and the plastic parts may incur damage. In line with the prevailing conditions, take countermeasures such as tailoring the installation conditions in accordance with the conditions, using air conditioner designed for kitchens or oil guard filters, etc.

- Locations with disinfectant-induced chlorine atmospheres (water tanks, etc.) The metal parts in the heat exchangers, motors, etc., may become corroded.

- Locations with high salinity (coastal areas, etc.) Corrosion may occur so use outdoor units specifically designed to withstand exposure to salt.

- Locations where power is supplied from independent power generators. The power line frequency and/or voltage may fluctuate, possibly causing the air conditioner to malfunction.

- Locations where high frequencies or electrical noise is generated (from high-frequency welders used for vinyl welding and processing, high-frequency therapeutic devices used for thermotherapy, etc.) The electronic components may be adversely affected, possibly causing the air conditioner to malfunction.

- Locations where electronic equipment is installed. Electrical noise may adversely affect the operation of the electronic equipment.

(3) Concerning use in locations with high ceilings

- In locations with high ceilings, use of circulators for improving the temperature distribution during heating is recommended.

(4) Concerning use in high-humidity environments

- When the ceiling-recessed type of indoor unit is installed in a location, such as those described below, and it is very hot and humid inside the ceiling, condensation may form on the external surfaces of the indoor unit and drip down. In such cases, add external heat-insulating materials.

- Locations such as food preparation sites in which the areas above the ceilings are hot and humid.

- Locations in which outside air is drawn in and routed above the ceiling

- Above ceilings with a slate roof or tiled roof overhead

(5) Concerning use in high-humidity environments

- When the ceiling-recessed type of indoor unit is installed in a location, such as those described below, and it is very hot and humid inside the ceiling, condensation may form on the external surfaces of the indoor unit and drip down. In such cases, add external heat-insulating materials.

- Locations such as food preparation sites in which the areas above the ceilings are hot and humid

- Locations in which outside air is drawn in and routed above the ceiling

- Above ceilings with a slate roof or tiled roof overhead.

Toshiba VRF and direct expansion solutions are available through
AHI Carrier in over 96 countries

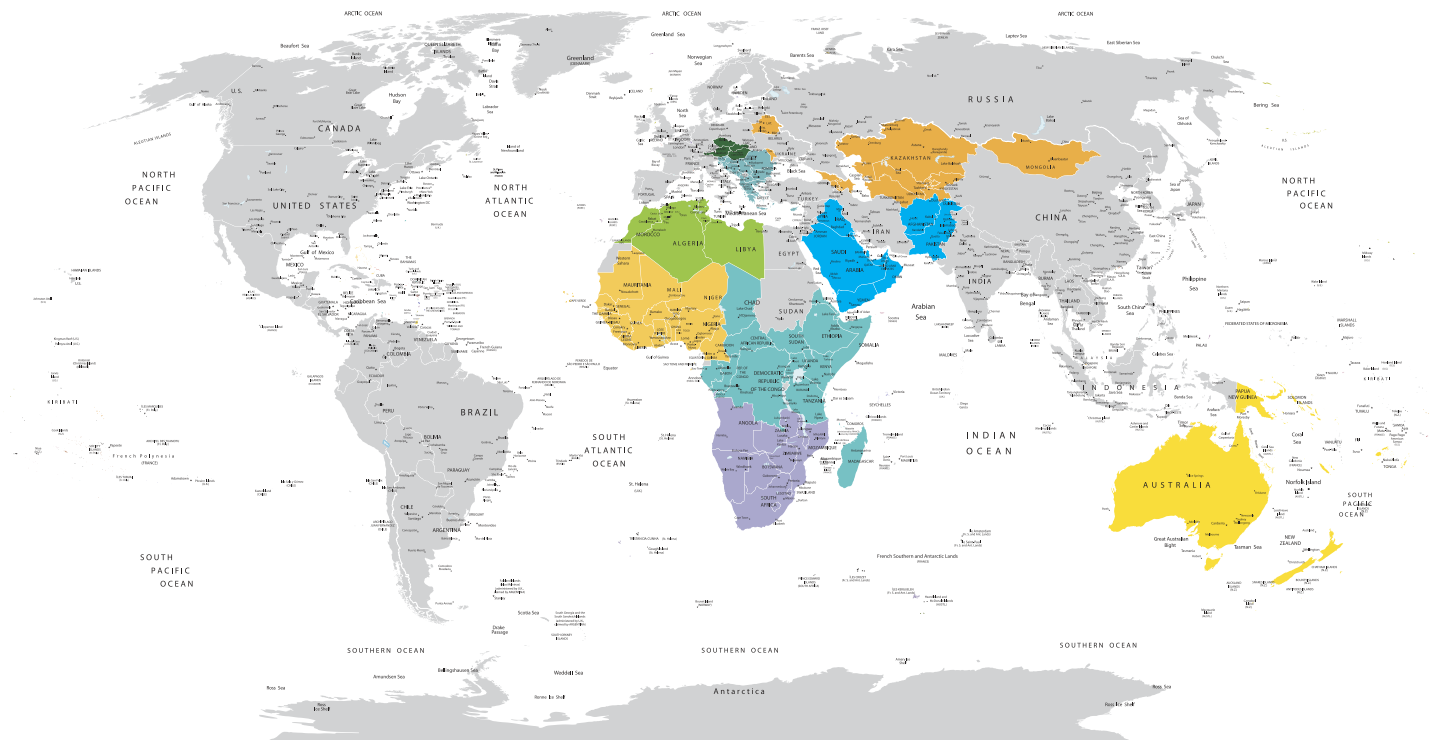

Middle East

Afghanistan, Bahrain, Iraq, Kuwait, Oman, Pakistan, Qatar, Saudi Arabia, UAE, Yemen.

Central & East Africa

Burundi, Chad, Democratic Republic of Congo, Central African Republic, Djibouti, Eritrea, Ethiopia, Gabon, Kenya, Republic Of Congo, Rwanda, South Sudan, Somalia, Tanzania, Uganda, Mauritius, Seychelles, Mauritania, Madagascar, Reunion Island, Comoros.

Western Africa

Ivory Coast, Nigeria, Ghana, Burkino Faso, Senegal, Liberia, Mali, Niger, Sierra Leone, Guinea Bissau, Benin, Togo, Cameroon, Guinea, Cape Verde, Equatorial Guinea, Gambia, Sao Tome and Principe.

Northern Africa

Tunisia, Algeria, Libya, Morocco.

Southern Africa

Mozambique, Angola, Lesotho, Swaziland, Namibia, Zambia, South Africa, Botswana, Malawi, Zimbabwe.

Russia & Other CIS

Armenia, Azerbaijan, Belarus, Georgia, Kazakhstan, Kyrgyzstan, Moldova, Mongolia, Tajikistan, Turkmenistan, Uzbekistan.

Greece & the Balkans

Greece, Romania, Bulgaria, Cyprus, Albania, Bosnia-Herzegovina, Serbia, Croatia, Slovenia, Montenegro, Fyr Macedonia.

Central & Eastern Europe

Austria, Czech Republic, Slovakia, Hungary.

Australia & New Zealand

Australia, Torress Strait Island, Christmas Island, Norfork Island, Tasmania, New Zealand, New Caledonia, Papua New Guinea, Fiji, Tahiti, Samoa, Cook Islands, Tonga, Vanuatu, Solomon Islands.

TOSHIBA

AIR CONDITIONING

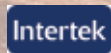
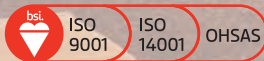

Tested at 3rd party laboratory
(Intertek,USA)



Notice:

Product listed in this catalogue use HFC refrigerant R410A with a GWP of 2,088*. Toshiba is committed to continuously improving its products to ensure the highest quality and reliability standards and to meet local regulations and market requirements. All features and specifications are subject to change without prior notice.

* The GWP value is calculated based on information provided in the EU F-gas Regulation and IPCC Fourth Assessment Report.